

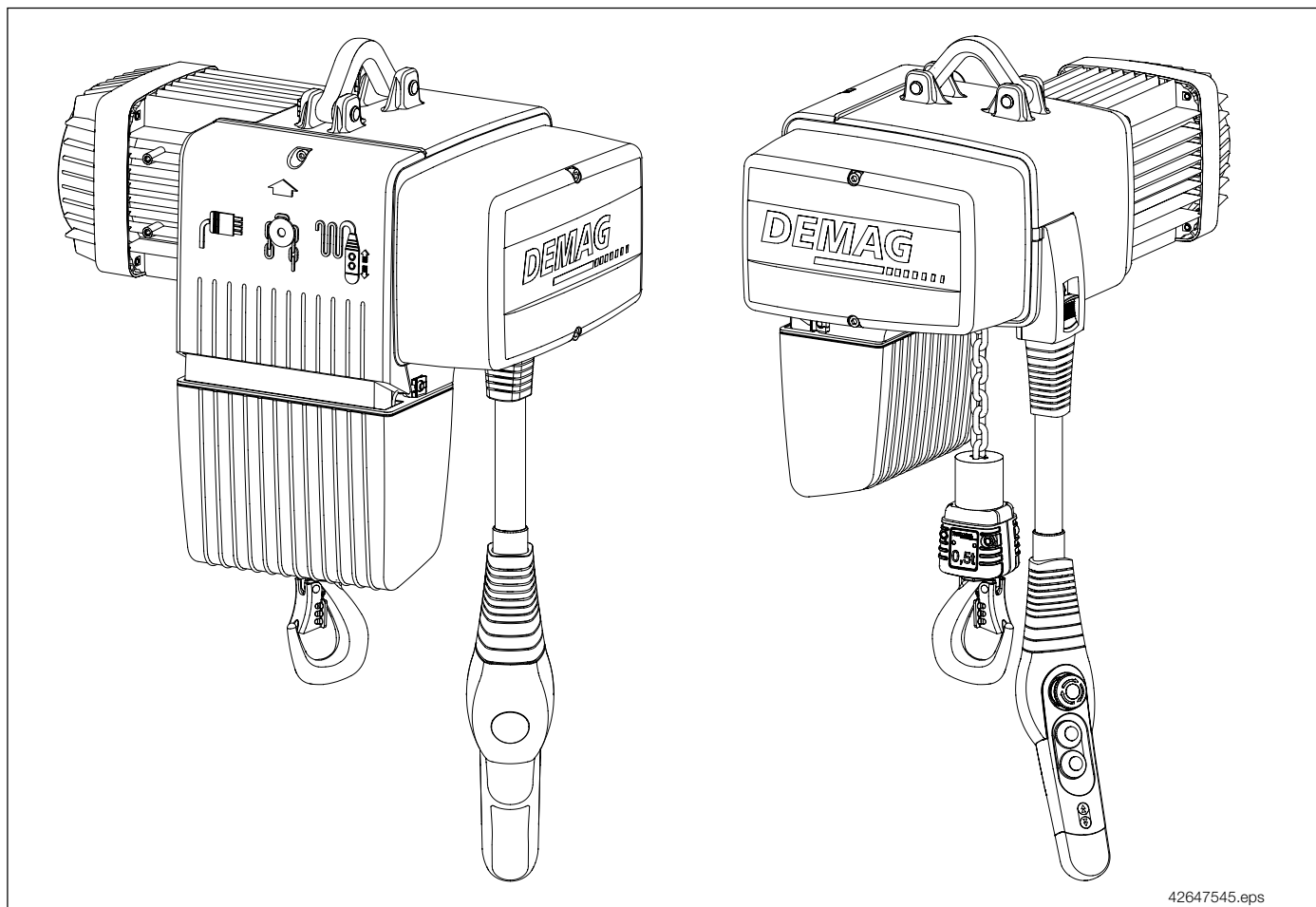

Operating instructions/component parts

Demag chain hoist DC-Pro 1, DC-Pro 2, DC-Pro 5, DC-Pro 10, DC-Pro 20

Demag chain hoist Manulift DCM 1 – DCM 2 – DCM 5



Manufacturer

Demag Cranes & Components

29201 Aurora Road · Solon, Ohio 44139
Telephone (440) 248-2400 · Fax (440) 248-3086
www.demag-us.com

Please fill in the following table before first putting the chain hoist into service.
This provides you with a definitive documentation of your chain hoist and important information if you ever have to contact the manufacturer or his representative.

Owner	_____
Where in use	_____
Size	_____
Serial number	_____

Accompanying documents

Technical data

Demag chain hoist DC- Pro 1 to DC 20	900 432 49	714 IS 817
CF5 Technical data-Assembly-Component parts	203 568 44	714 IS 845
U11/U22 Technical data-Assembly-Component parts	203 569 44	714 IS 845
Clamp-fitted buffer	203 313 44	714 IS 888

Operating instructions – Assembly – Setting – Dimensions

DSE assembly instructions	214 214 44	720 IS 951
DSE-C assembly instructions	214 786 44	720 IS 951
E11/22 travel drive unit operating instructions	214 810 44	720 IS 845
Test and inspection booklet	214 745 44	720 IS 817
Certificates	235 310 44	

Contents

0	Foreword	4
0.1	Copyright	4
0.2	After-sales service	4
0.3	Liability for defects	4
0.4	Limitations of liability	5
0.5	Definitions	6
1	Safety instructions	7
1.1	Symbol description	7
1.2	Intended use	7
1.3	Inappropriate use	8
1.4	Basic information on safety	8
1.5	Selection and qualification of operating and maintenance personnel	9
1.6	Safety instructions for installation and disassembly	9
1.7	Safety instructions on first putting into service after completing installation	10
1.8	Safety instructions for operation	10
1.9	Safety instructions for maintenance	11
2	Technical data	12
2.1	Design overview	12
2.2	Model code	12
2.3	Selection table	13
2.4	Electrical key values	14
2.5	Hook dimension C	16
2.6	Sound pressure level	18
2.7	Transportation and storage	18
2.8	Surface protection and painting	18
2.9	Operating conditions	18
3	Description	19
3.1	Design	19
3.2	Drive	19
3.3	Gearing and slipping clutch	20
3.4	Chain drive	20
3.5	Housing	20
3.6	Electrical equipment	20
3.7	Central service enclosure	21
3.8	Control pendant height adjustment	21
3.9	Control pendant	21
3.10	DCM Manulift with quick-change coupling	22
3.11	Suspension	24
3.12	Trolley	26
4	Installation and putting into operation	28
4.1	General	28
4.2	Connecting the control pendant	29
4.3	Suspending the chain hoist	30
4.4	Control pendant height adjustment	31
4.5	Mains connection	32
4.6	Setting the bottom hook position	34
5	Taking the unit out of service at the end of the shift/for maintenance	35
5.1	Emergency stop	35
5.2	Taking the unit out of service at the end of the shift	35
5.3	Taking the unit out of service for maintenance	35
6	Inspections/maintenance/general overhaul GO	36
6.1	Inspection before starting work and during operation	36
6.2	Inspection and maintenance schedule	36
6.3	Operating status and error display	36
6.4	General overhaul GO	36
6.5	Inspection and maintenance schedule	37
6.6	Display of operating hours / statuses	38
7	Maintenance	40
7.1	Replacing the hook	40
7.1.1	1/1 reeving	40
7.1.2	Replacing the bottom block for 2/1 reeving, DC-Pro 20	41
7.2	Dismantling the chain set	42
7.3	Dismantling the chain collector box	44
7.4	Hoist chain	46
7.5	Load hook, suspension bracket, trolley crossbar	48
7.6	Brake	48
7.7	Checking and adjusting the slipping clutch	49
7.8	Replacing the cables	50
7.9	Circuit diagrams and control card	52
7.10	Warning messages and error statuses	55
7.11	Instructions for finding faults	56
8	Component parts	58
	Declaration of conformity	67

0 Foreword



You have purchased a Demag quality product.

This chain hoist was manufactured to European standards and regulations in accordance with state-of-the-art engineering principles.

These operating instructions are designed to provide the owner and operator with useful instructions for transportation, putting into service, operation and maintenance of our chain hoists.

Persons entrusted with this work must know and comply with the safety regulations and the operating instructions.

The operating instructions must be available to the operating personnel at all times in order to prevent operating errors and to ensure smooth and trouble-free operation of our products.

0.1 Copyright

These operating instructions are protected within the sense of copyright law.

No part of this documentation may be reproduced, utilized or transmitted without specific prior consent.

0.2 After-sales service

Should you have any questions regarding application or in the event of errors, contact our after-sales service:

Demag Cranes & Components

(440) 248-2400

For information on our products, please refer to one of our Demag offices, the relevant representative, authorized resellers, head office in Cleveland or the Internet:

www.demag-us.com

By quoting the serial number, the type or the order number of your Demag chain hoist, you enable us to process any enquiries or spare parts orders without delay.

0.3 Liability for defects

These operating instructions must be read carefully before installing and putting the chain hoist into operation.

We assume no liability for any damage and malfunctions resulting from failure to comply with the operating instructions.

Liability claims for defects must be made by quoting the order number immediately on detecting the defect.

Any liability claims for defects are void in the event of:

- inappropriate use,
- faulty devices or equipment connected or attached to the product which are not part of our scope of supplies and services,
- use of non-genuine spare parts and accessories,
- refurbishment or modification of the product unless approved in writing by Demag.

Wearing parts are not subject to liability for defects.

0.4 Limitations of liability

All technical information, data and instructions for operation contained in these operating instructions were up-to-date on going to print and are compiled on the basis of our experience and to the best of our knowledge.

We reserve the right to incorporate technical modifications within the scope of further development of the chain hoists which are the subject of these operating instructions.

The information, illustrations and descriptions contained in these operating instructions are therefore only intended for information purposes.

The descriptions and illustrations contained in these operating instructions do not necessarily correspond to the scope of delivery or any subsequent spare part delivery, either; the drawings and illustrations are not to scale.

Only documentation belonging to the actual order is valid.

We assume no liability for defects, damage and malfunctions caused as a result of operating errors, noncompliance with these operating instructions or omitted and/or inappropriate repairs and maintenance.

We expressly point out that only the use of genuine Demag parts and accessories approved by us ensures safe operation. Accordingly, this also applies to other manufacturers' parts used.

For safety reasons, the fitting and use of spare parts or accessories which have not been approved and unauthorized modification and conversion of the product are not permitted and exempt Demag from any liability for defects or damages resulting therefrom.

With the exclusion of any further claims, Demag Cranes & Components is liable for any faults or omissions on our part in the products or documentation supplied within the scope of the liability for defects obligations entered into in the original contract. With the exception of legal claims according to relevant product liability legislation, claims for damages are excluded, regardless of the legal reason from which such claims are derived.

0.5 Definitions

Owner

Owners (employer, company) are defined as persons who own the chain hoist and who use it appropriately or allow it to be operated by suitable and trained persons.

Operating personnel/operator

Operating personnel are defined as persons entrusted by the owner of the chain hoist with operation of the equipment.

Specialist personnel

Specialist personnel are defined as persons assigned by the owner of the chain hoist to carry out special tasks such as installation, setting-up, maintenance and fault elimination.

Qualified electrician

Qualified electricians are defined as persons who, owing to their technical training, knowledge and experience of electrical installations as well as knowledge of the relevant standards, codes of practice and regulations, are able to assess the tasks given to them and to identify and eliminate potential hazards.

Trained person

Trained persons are defined as persons who have been instructed and trained for the tasks assigned to them and on the possible hazards resulting from incorrect handling and who have been informed about the required protective devices, protective measures, relevant regulations, codes of practice, accident prevention regulations and operating conditions and who have proven their qualifications.

Experienced technician

Experienced technicians are defined as persons, who, owing to their technical training and experience, have sufficient knowledge of chain hoists and are familiar with the relevant national industrial safety regulations, codes of practice, accident prevention regulations, directives and generally accepted engineering standards enabling them to judge the safe operating condition of a chain hoist.

1 Safety instructions

1.1 Symbol description

These symbols and instructions are used to warn against potential safety hazards or causes of damage or provide useful information.



Hazard warning

This symbol indicates all instructions relating to safety at work. Any failure to comply with these instructions will result in danger to life and limb. Follow these instructions at all times and be particularly vigilant and cautious.



Warning against dangerous electrical voltage

Contact with live parts can result in immediate death. Access (e.g. opening of covers and enclosures of electrical equipment) only by qualified personnel after the stipulated protective measures have been taken.



Warning against suspended load

Any person remaining in this danger zone may suffer serious injury or death.



Operating hazard for the installation

This symbol indicates information on the appropriate use of machinery. It indicates all warnings which, if not complied with, may result in damage to the chain hoist or the load.



Information

This symbol indicates tips and useful information.

1.2 Intended use

Chain hoists are only intended for lifting, lowering and moving loads and may be used as stationary or travelling units. The suspension/support structure for the chain hoist must be designed for loads caused by operation of the chain hoist.

The chain hoists are designed for a period of use of at least 10 years until the first general overhaul is carried out. This is based on the condition that the specified group of mechanisms is not exceeded by the actual duration of service. When the actual duration of service has reached the theoretical duration of service valid for the group of mechanisms, further operation of the chain hoist is only permissible after a general overhaul.



The chain hoists are supplied with power from an AC power network. The voltage and frequency of the AC power network must match the data specified on the rating plate of the chain hoist. It must be possible to switch off powerfeed by means of a device for disconnecting the powerfeed.

Electric chain hoists must only be operated when in perfect working order by trained operating personnel. The relevant safety and accident prevention regulations as well as the operating instructions must be complied with.



The load specified on the capacity plate indicates the highest permissible load which must not be exceeded by the sum total of lifting load and load handling attachment. Only approved load handling attachments may be used. The load capacity of the load handling attachment must not be exceeded.

The powered motions of lifting and lowering and, if applicable, cross travel and long travel are controlled by means of the corresponding control elements of the control pendant. The slow speeds are intended for attaching the load, lifting it free and depositing it. Loads can be precisely positioned at slow speeds. At fast speeds, short transport times can be reached. They are suitable for travelling without load or safely suspended load, if no hazard may be caused by the faster motion sequences.



Inching is to be avoided at fast speeds, as it causes increased wear and load sway.

1.3 Inappropriate use



Certain work and practices are prohibited when using the chain hoist as they may result in serious injury or death and damage to the chain hoist, e.g.:

- Unsafe load handling (e.g. swinging the load).
- Do not handle suspended loads above persons.
- Do not pull or drag suspended loads at an angle.
- Do not pull free fixed or obstructed loads.
- Do not exceed the maximum permitted load and permitted load dimensions.
- Do not leave suspended loads unsupervised.
- Do not touch the chain while lifting or lowering the load.
- Do not allow chains to run over edges.
- Do not use the chain as a load bearing sling.
- Do not move loads by dragging on the control pendant.
- Do not allow loads to drop when the chain is in a slack condition.
- Do not subject the control pendant to inappropriate mechanical loads.
- Do not allow the control cable to be wound around the chain when lifting motions are performed.
- Transporting persons, unless lifting devices are specifically approved for transporting persons, is not permitted.
- Do not manipulate electrical equipment.
- Chain hoists must be suspended in such a way that they do not collide with stationary equipment and structures, e.g. when slewing pivoting cranes.
- The bottom block must not be twisted or turned over for 2/1 reeving arrangements; chain links facing the same direction must be arranged opposite each other without being twisted.

1.4 Basic information on safety



The owner must ensure that the chain hoist is only operated when in proper working order and that the relevant safety requirements and regulations are complied with.

Chain hoists must be taken out of service immediately if functional defects or irregularities are detected. If the chain hoist has been stopped as a consequence of safety-relevant defects, it must be secured against putting into operation again until an experienced technician is satisfied that the cause of the hazard situation has been eliminated and that operation of the installation is possible without any hazard.

To avoid accidents and damage, observe general statutory and other obligatory regulations relating to accident prevention and environmental protection and basic health and safety requirements as well as these operating instructions. Important information and instructions are marked by corresponding symbols. The operating instructions must be kept available at the place where they are available for information to the operating personnel responsible at all times.



If the operating and safety instructions are not observed in any way, personal injury or even death can result. The owner must instruct his personnel accordingly.

Special local conditions or applications can lead to situations which are not taken into consideration in these operating instructions. In such cases, the required safety measures must be determined and implemented by the owner. Necessary measures may also relate, for example, to the handling of hazardous materials or tools and the provision/wearing of personal protection equipment.

The operating instructions must, if required, be supplemented by the owner with instructions relating to the organization of work, working procedures, authorized personnel, supervising and reporting obligations, etc..

Hazards for persons and property may be caused by chain hoists which are not installed, operated and maintained appropriately or operated by unsuitable personnel.

Persons under the influence of drugs, alcohol or medicines which affect reactions must not install, put into service, operate, maintain, repair or disassemble chain hoists.



Any conversions and modifications to the installation require the written consent of Demag. This also applies to the installation and adjustment of safety devices as well as for performing welds on load bearing parts. Safety devices must not be rendered inoperative. All safety and hazard information on the chain hoist, at access points and mains connection switches must be maintained in complete and legible condition.

Installation, repair and maintenance work relating to chain hoists which are not described in these operating instructions may only be carried out by qualified specialist personnel with the specified equipment.

Work on electrical equipment of chain hoists may only be carried out by qualified electricians in accordance with electrical regulations.

Only genuine spare parts and accessories that have been approved by Demag may be used. In the circuits, only genuine fuse links with the specified amperage and tripping characteristics may be used. Defective fuse links must not be bridged.

Observe prescribed deadlines or those specified in the operating instructions for routine checks/inspections.

1.5 Selection and qualification of operating and maintenance personnel



For independent operation or maintenance of the chain hoist, the owner may only employ persons

- who are mentally and physically suitable,
- who have been instructed in the operation or maintenance of the chain hoist and have proven their qualification to the owner in this respect (this also includes practical application and the ability to identify defects which are a hazard to safe operation),
- who can be expected to carry out the work assigned to them reliably.

If the chain hoist is used as the hoist unit in a crane, operating persons must also be at least 18 years of age.

1.6 Safety instructions for installation and disassembly



- Installation and disassembly work may only be performed by experienced technicians.
- Installation and disassembly work must be co-ordinated by the person carrying out the work and the owner within the scope of their responsibility.
- The working and danger zone must be made safe.
- The installation must be isolated in accordance with the relevant electrical regulations.
- Customer-specific regulations must be observed.
- Only appropriate, tested and calibrated tools and equipment may be used.
- The electrode holder and earth must be connected to the same assembly when welding work is carried out (if the current flow is returned via protective conductors, screening elements or anti-friction bearings, serious damage may be caused to these or other components).

1.7 Safety instructions when first putting the unit into service after completing installation



- The working and/or danger zone must be made safe.
- Before the chain hoist is first put into operation, an experienced technician must carry out the following checks:
- The voltage and frequency specified on the capacity plates must match the owner's mains power supply.
 - The supporting structure must be in proper condition and be sufficiently rated for the load capacity of the chain hoist.
 - Safety devices must be completely fitted and effective.
 - Clearances and safety distances must be complied with.
 - The emergency stop device must be checked by actuating the emergency stop button.

When a chain hoist is operated on a crane, these checks must be carried out by an expert engineer.

1.8 Safety instructions for operation



Before starting operation of the chain hoist, it must be ensured that nobody is endangered by operation of the hoist. If the operator notices that persons are endangered during operation, he must suspend operation until the persons have left the danger zone.



When starting work, the operator must be satisfied that the chain hoist is in safe and correct operating condition. This includes checking the function of the brakes, end position limitations and emergency stop devices. All protection devices must have been installed and must be fully functioning.

In the event of defects which endanger safe and reliable operation, the chain hoist must be taken out of service without delay. Defects relevant to safety in this sense are, for example:



- Damage to electrical devices, cables or insulation,
- Delayed functioning or failure of brakes and safety devices,
- Missing covers or housing parts,
- Damage to the chain or to supporting parts.

Anybody who identifies an immediate danger of personal injury must actuate the emergency stop button without delay. This also applies in the case of damage occurring to parts of the installation and equipment which makes immediate stoppage necessary.

If the chain hoist has been stopped as a consequence of safety-relevant defects, it must be secured against putting into operation again until an experienced technician is satisfied that the cause of the hazard situation has been eliminated and that operation of the installation is possible without any hazard.

Functioning of the emergency stop device

When the emergency stop button is actuated, the hoist motor is disconnected immediately from the electrical power supply, the mechanical brake is applied and stops the movement. Resuming operation by unlatching the emergency stop button is only possible, if no lifting or lowering commands are applied (off-position constraint). The effectiveness of the emergency stop function depends on the proper condition of the mechanical brake.



If an unusually long braking distance is noted, impermissible wear on the brake may be the cause. In this case, the brake must be inspected by an experienced technician without delay.



Functioning of the slip clutch

The chain hoist is fitted with a slip clutch that is tripped in the event of overload. The brake is then automatically applied and the motor is switched off. In this situation, only lowering is still possible. It is therefore not possible to lift an overload from the ground. A load already suspended can be safely deposited by actuating the lowering button. When the lowering motion has been completed, lifting is possible again.

If the slip clutch switches off already at rated load, the slip force must be measured by an experienced technician and re-adjusted, as required.



Functioning of the upper and lower limit switch

After the upper and lower limit switch has been tripped, only the opposite motion is still possible. The lifting path is limited by limit stops on the ends of the chain. As a consequence, the slip clutch becomes effective as an emergency stop device, the brake is automatically applied and the motor is switched off. Tripping of the emergency stop device causes a warning message on the display. Limit switch contacts prevent travelling against the emergency stop device, they are actuated by elastic buffers on the limit stop and cut-out the motion before the emergency stop device is reached.

1.9 Safety instructions for maintenance

The owner of the chain hoist must ensure that the specified maintenance work is carried out appropriately on the chain hoist. Maintenance measures are defined as regular maintenance, inspection and repair work.

Maintenance work must be carried out by sufficiently qualified specialist personnel (experienced technicians). Unauthorized personnel must not be allowed to carry out maintenance work on the chain hoist.

The necessary inspection, adjustment and maintenance work and the relevant time intervals are specified in the operating instructions, section 6.



Before starting any maintenance work, the chain hoists must be switched off and taken out of service and secured against accidental or unauthorized putting into operation (restarting), unless specified otherwise in section 6. Switches must be locked.



It must be ensured that

- the chain hoist is switched off, checked that it is de-energized and, in special cases, isolated,
- moving parts are stationary and stopped,
- moving parts cannot start moving while maintenance work is being carried out,
- the power supply cannot be accidentally restored,
- operating and auxiliary materials as well as replacement parts are appropriately disposed of.

Instructions for repair work in the course of operation

If maintenance work on the chain hoist must be carried out in the course of operation, special safety precautions are necessary, depending on the operating situation.



In each individual case, the owner or the person assigned by him must check whether the maintenance work may be carried out in the course of operation without risk of personal injury and, taking into account the local conditions, implement all necessary safety precautions.

2 Technical data

2.1 Design overview

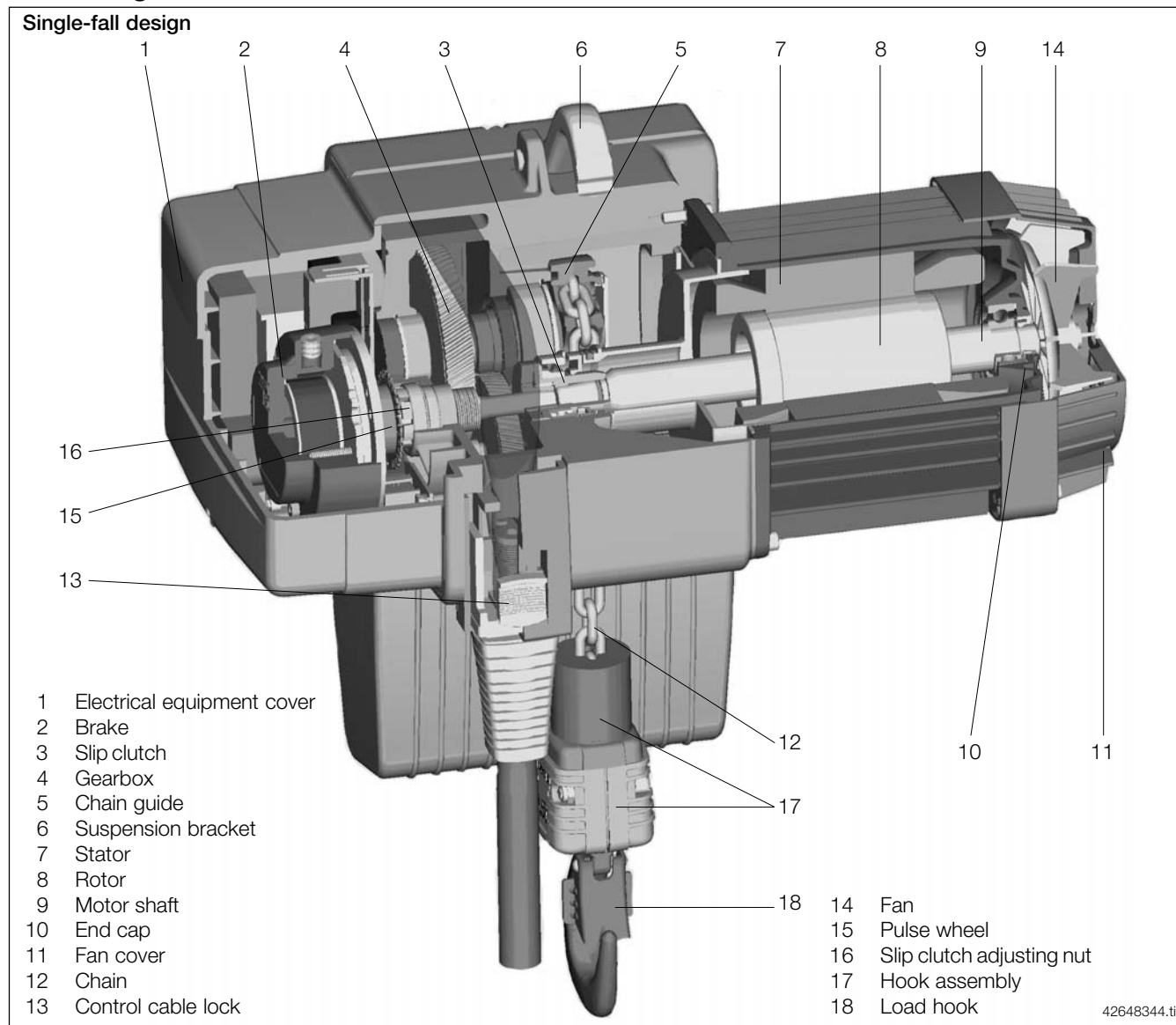

2.2 Model code

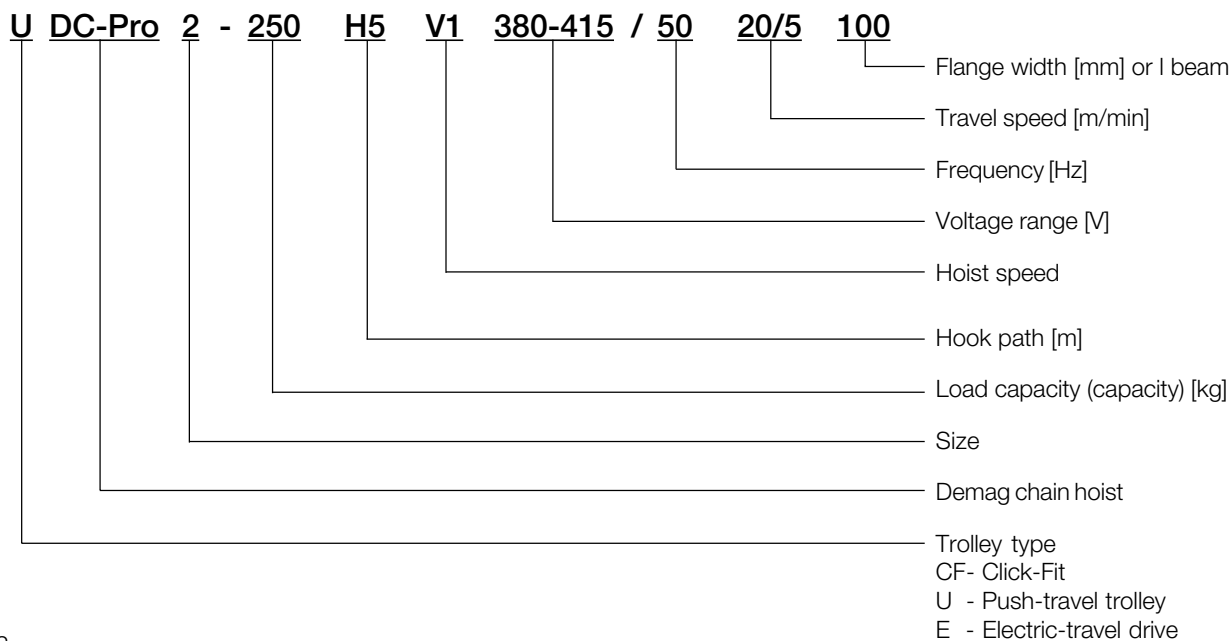

2.3 Selection table

SWL lb [kg]	Chain hoist Type	Hoist speed ft/min at 60 Hz [m/min at 60 Hz]	Motor size ¹⁾	Hook path ft [m]	Group of mechanisms FEM	Reeving	Max. weight	
							16 ft [5 m]	26 ft [8 m]
275 [125]	DC-Pro 1 -...V1	32/8 [9.6/2.4]	ZNK 71 B 8/2	16 and 26 [5 and 8]	4m	1/1	48.5 [22]	50 [24]
	DC-Pro 2 -...V2	64/16 [19.2/4.8]						
550 [250]	DC-Pro 2 -...V1	32/8 [9.6/2.4]	ZNK 80 A 8/2		2m+ ²⁾		48.5 [22]	50 [24]
	DC-Pro 5 -...V2	48/12 [14.4/3.6]			4m		62 [28]	66 [30]
1100 [500]	DC-Pro 5 -...V1	24/6 [7.2/1.8]	ZNK 80 A 8/2		2m+ ²⁾		48.5 [22]	50 [24]
	DC-Pro 10 -...V2	48/12 [14.4/3.6]	ZNK 100 A 8/2		4m		120 [54]	128 [58]
2200 [1000]	DC-Pro 10 -...V1	24/6 [7.2/1.8]	ZNK 100 A 8/2		2m+ ²⁾³⁾		106 [48]	115 [52]
	DC-Pro 20 -...V2	48/12 [14.4/3.6]	ZNK 100 B 8/2				110 [50]	120 [54]
4400 [2000]	DC-Pro 20 -...V1	24/6 [7.2/1.8]					2m+ ²⁾	2/1

1) For motor key data, see section 2.4.

2) 2m+ corresponds to a service life of 1900 hours at full load.

3) 1Am chain drive arrangement

SWL lb [kg]	Manulift Type	Hoist speed ft/min at 60 Hz [m/min at 60 Hz]	Motor size ¹⁾	Hook path ft [m]	Group of mechanisms FEM	Reeving	Max. weight	
							lb [kg]	
175 [80]	DCM-Pro 1 - ... V1	32/8 [9.6/2.4]	ZNK 71 B 8/2	9.2 and 14 [2.8 and 4.3]	4m	1/1	48.5 [22]	
	DCM-Pro 2 - ... V2	64/16 [19.2/4.8]						
275 [125]	DCM-Pro 1 - ... V1	32/8 [9.6/2.4]						
	DCM-Pro 2 - ... V2	64/16 [19.2/4.8]						
550 [250]	DCM-Pro 2 - ... V1	32/8 [9.6/2.4]	ZNK 80 A 8/2		2m+ ²⁾		4m	62 [28]
	DCM-Pro 5 - ... V2	48/12 [14.4/3.6]						

1) For motor key data, see section 2.4.

2) 2m+ corresponds to a service life of 1900 hours at full load.

2.4 Electrical key values

Hoist motor data (The tolerance of the voltage range must not exceed $\pm 10\%$.)

Size	Motor Size	Number of poles	Min. / max. currents and starting current													
							460-480 V, 60 Hz, 3 ~					440-455 V, 60 Hz, 3 ~				
			P _N	CDF	η_N	Starts/h	I _{N 460}	I _{N 480}	I _{max} ¹⁾	I _A /I _{N 480}	cos φ_N	I _{N 440}	I _{N 455}	I _{max} ¹⁾	I _A /I _{N 455}	cos φ_N
HP	[%]	[rpm]		[A]	[A]	[A]			[A]	[A]	[A]					
DC-Pro 1	ZNK 71 B 8/2	8	0.08	20	870	240	1.00	1.20	1.20	1.45	0.47	0.96	1.15	1.15	1.45	0.47
		2	0.29	40	3525	120	1.20	1.60	1.60	2.75	0.45	1.15	1.55	1.55	2.75	0.45
DC-Pro 2	ZNK 71 B 8/2	8	0.15	20	825	240	1.00	1.20	1.35	1.45	0.55	1.05	1.25	1.40	1.45	0.55
		2	0.59	40	3425	120	1.40	1.60	1.85	2.75	0.62	1.45	1.65	1.95	2.75	0.62
DC-Pro 5	ZNK 80 A 8/2	8	0.23	20	860	240	1.15	1.30	1.45	2.10	0.47	1.20	1.35	1.50	2.10	0.47
		2	0.90	40	3480	120	2.40	2.90	3.40	4.35	0.56	2.50	3.00	3.55	4.35	0.56
DC-Pro 10	ZNK 100 A 8/2	8	0.43	20	840	240	1.70	1.90	2.20	1.80	0.53	1.80	1.95	2.30	1.80	0.53
		2	1.74	40	3345	120	3.10	3.10	3.50	3.60	0.80	3.25	3.20	3.70	3.60	0.80
DC-Pro 20	ZNK 100 B 8/2	8	0.87	20	880	240	3.80	4.20	4.90	2.33	0.46	4.00	4.40	5.10	2.33	0.46
		2	3.62	40	3535	120	5.80	6.40	7.70	4.75	0.59	6.10	6.70	8.10	4.75	0.59

Size	Motor Size	Number of poles	Min. / max. currents and starting current									
							220-240 V, 60 Hz, 3 ~					
			P _N	CDF	η_N	Starts/h	I _{N 220}	I _{N 240}	I _{max} ¹⁾	I _A /I _{N 240}	cos φ_N	
HP	[%]	[rpm]		[A]	[A]	[A]						
DC-Pro 1	ZNK 71 B 8/2	8	0.08	20	870	240	2.10	2.50	2.50	1.45	0.47	
		2	0.29	40	3525	120	2.50	3.35	3.35	2.75	0.45	
DC-Pro 2	ZNK 71 B 8/2	8	0.15	20	825	240	2.10	2.50	2.80	1.45	0.55	
		2	0.59	40	3425	120	2.90	3.30	3.85	2.75	0.62	
DC-Pro 5	ZNK 80 A 8/2	8	0.23	20	860	240	2.40	2.70	3.00	2.10	0.47	
		2	0.90	40	3480	120	5.00	6.00	7.10	4.35	0.56	
DC-Pro 10	ZNK 100 A 8/2	8	0.43	20	840	240						
		2	1.74	40	3345	120						
DC-Pro 20	ZNK 100 B 8/2	8	0.87	20	880	240						
		2	3.62	40	3535	120						

1) I_{max} = maximum rated current for lowering operation.

Size	Motor Size	Number of poles	Min. / max. currents and starting current							
							575 V, 60 Hz, 3 ~			
			P _N	CDF	η _N	Starts/h	I _{N 575}	I _{max} ¹⁾	I _A /I _{N 575}	cos φ _N
			HP	[%]	[rpm]		[A]	[A]		
DC-Pro 1	ZNK 71 B 8/2	8	0.08	20	870	240	1.10	1.10	1.22	0.49
		2	0.29	40	3525	120	1.20	1.20	3.50	0.41
DC-Pro 2	ZNK 71 B 8/2	8	0.15	20	825	240	1.00	1.15	1.34	0.53
		2	0.59	40	3425	120	1.20	1.40	3.50	0.65
DCPro 5	ZNK 80 A 8/2	8	0.23	20	860	240	1.00	1.15	2.15	0.46
		2	0.90	40	3480	120	2.25	2.70	5.00	0.59
DC-Pro 10	ZNK 100 A 8/2	8	0.43	20	840	240	1.60	1.90	2.00	0.53
		2	1.74	40	3345	120	2.50	2.80	3.90	0.82
DC-Pro 20	ZNK 100 B 8/2	8	0.87	20	880	240	3.60	4.20	2.70	0.43
		2	3.62	40	3535	120	5.40	6.60	5.40	0.63

Mains connection delay fuse links

Motor Size	460-480V 60Hz	440-455V 60Hz	220-240V 60Hz	575V 60Hz
	[A]	[A]	[A]	[A]
ZNK 71 B 8/2	6	6	6	6
ZNK 80 A 8/2			10	
ZNK 100 A 8/2			-	
ZNK 100 B 8/2	10	10	-	10

Supply cables ²⁾ for 5% voltage drop Δ_U and starting current I_A

Motor Size	460-480V 60Hz		440-455V 60Hz		220-240V 60Hz		575V 60Hz	
	[mm ²]	[m]	[mm ²]	[m]	[mm ²]	[m]	[mm ²]	[m]
ZNK 71 B 8/2	1.5	100	1.5	100	1.5	79	1.5	100
ZNK 80 A 8/2						43		
ZNK 100 A 8/2					-	-		
ZNK 100 B 8/2					-	-		

90042649p3.p65/110205

1) I_{max} = maximum rated current for lowering operation.

2) The lengths of the supply lines are calculated on the basis of an earth-loop impedance of 200 mΩ .

2.5 Hook dimension C

DC-Pro chain hoist with suspension bracket

Size	Short suspension bracket			Long suspension bracket		
	C in [mm]	C1		C in [mm]	C1	
		Chain collector box - in [mm]			Chain collector box - in [mm]	
		H5	H8		H5	H8
DC-Pro 1	12.0 [305]	13.2 [335]	14.4 [365]	13.5 [343]	14.7 [373]	15.4 [403]
DC-Pro 2	12.0 [305]	13.2 [335]	14.4 [365]	13.5 [343]	14.7 [373]	15.4 [403]
DC-Pro 5	13.8 [350]	15.6 [395]	16.7 [425]	15.3 [388]	17.1 [435]	18.3 [465]
DC-Pro 10	18.1 [460]	19.4 [493]	22.9 [582]	19.4 [493]	20.7 [526]	24.2 [615]
DC-Pro 20	21.5 [547]	22.9 [582]	26.9 [682]	22.8 [580]	24.2 [615]	28.1 [715]

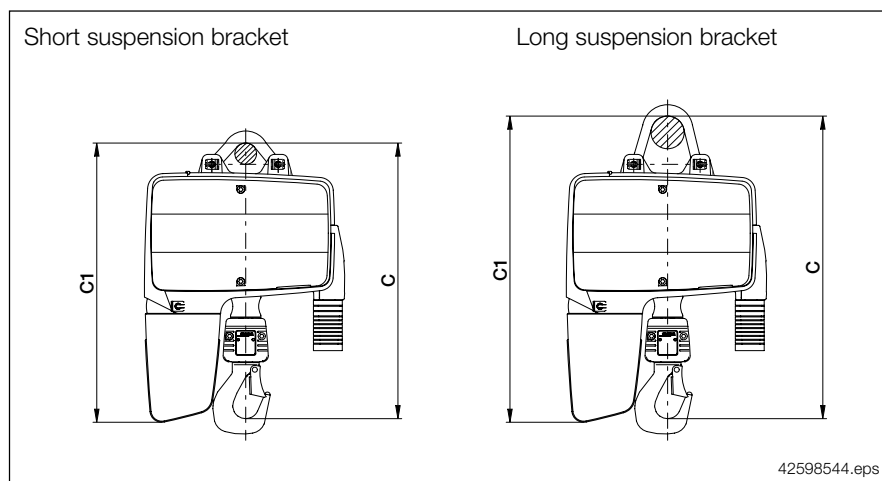

DCM-Pro Manulift chain hoist

Size	Short suspension bracket			Long suspension bracket		
	C		C1	C		C1
	for hook path			for hook path		
	9.2 ft [2.8 m]	14 ft [4.3 m]	Chain collector box - in [mm]	9.2 ft [2.8 m]	14 ft [4.3 m]	Chain collector box - in [mm]
		H5			H5	
DCM-Pro 1	25.9 [635]	27.8 [705]	13.2 [335]	26.5 [673]	29.2 [743]	14.7 [373]
DCM-Pro 2	25.9 [635]	27.8 [705]	13.2 [335]	26.5 [673]	29.2 [743]	14.7 [373]
DCM-Pro 5	26.8 [680]	29.5 [750]	15.5 [395]	28.2 [718]	31.0 [788]	17.1 [435]

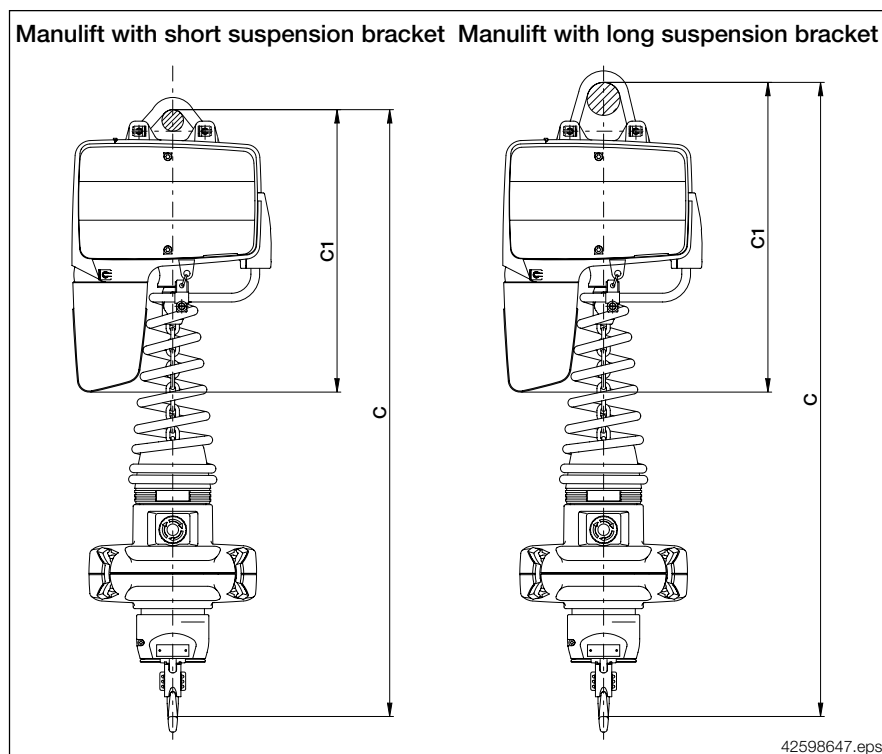

DC-Pro chain hoist with CF 5 trolley

Size	Right-angles to the girder			Parallel to the girder		
	C in [mm]	C1		C in [mm]	C1	
		Chain collector box - in [mm]			Chain collector box - in [mm]	
		H5	H8		H5	H8
DC-Pro 1	15.2 [385]	16.3 [415]	17.5 [445]	15.0 [380]	16.1 [410]	17.3 [440]
DC-Pro 2	15.2 [385]	16.3 [415]	17.5 [445]	15.0 [380]	16.1 [410]	17.3 [440]
DC-Pro 5	16.9 [430]	18.8 [477]	28.0 [507]	16.7 [425]	18.6 [472]	19.7 [502]

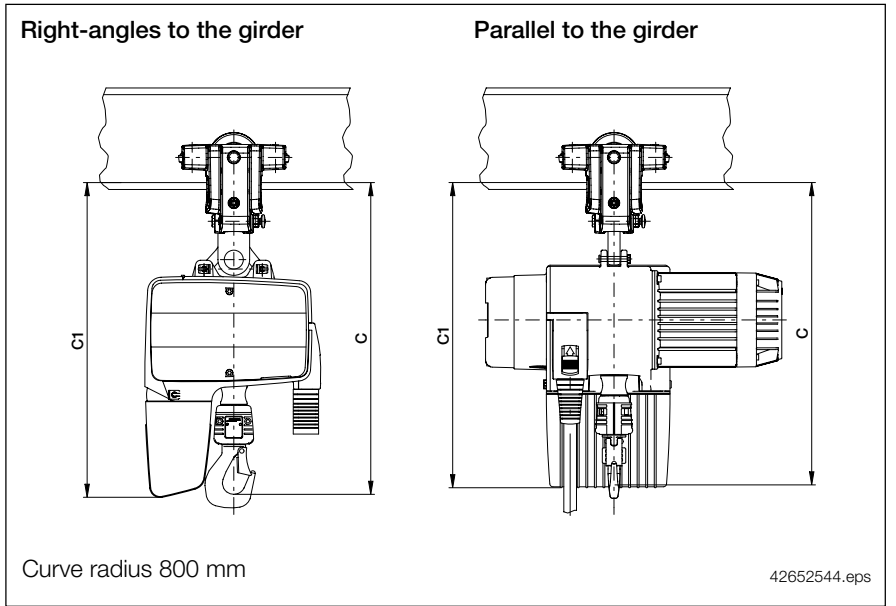

DC-Pro chain hoist with U 11 or U22 trolley

Size	Trolley	Right-angles to the girder			Parallel to the girder		
		C in [mm]	C1		C in [mm]	C1	
			Chain collector box in [mm]			Chain collector box in [mm]	
		H5	H8	H5	H8	H8	
DC-Pro 1	U 11	14.2 [360]	15.3 [390]	16.5 [420]	15.2 [385]	16.3 [415]	17.5 [445]
DC-Pro 2	U 11	14.2 [360]	15.3 [390]	16.5 [420]	15.2 [385]	16.3 [415]	17.5 [445]
DC-Pro 5	U 11	15.9 [405]	17.8 [452]	19.0 [482]	16.9 [430]	18.8 [477]	20.0 [507]
DC-Pro 10 ¹⁾	U 11	21.3 [545]	22.8 [578]	26.3 [667]			
	U 22	21.9 [557]	23.2 [590]	26.7 [679]			
DC-Pro 20 ¹⁾	U 11 ²⁾	21.5 [545]	22.8 [578]	26.3 [667]			
	U 22 ²⁾	21.9 [557]	23.2 [590]	26.7 [679]			
	U 22 ³⁾	25.3 [644]	26.7 [679]	30.7 [779]			

- 1) Dimensions C and C1 are reduced by 1.3 in (33 mm) if a short suspension bracket is used.
- 2) < 2200 lbs (1000 kg)
- 3) > 2200 lbs (1000 kg), 2/1 reeving

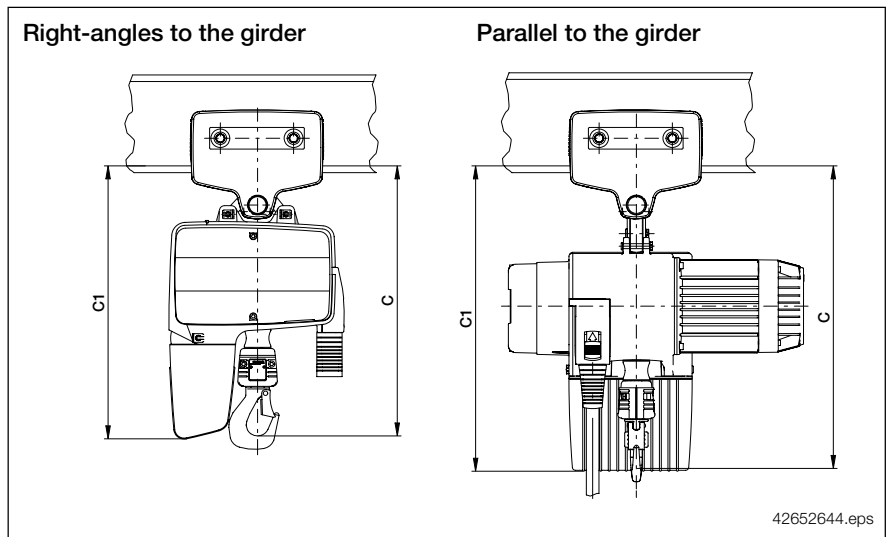

90042649p3.p65/110205

Minimum curve radius		
	Push travel in [mm]	Electric travel in [mm]
U 11	39.4 [1000]	78.7 [2000]
U 22	78.7 [2000]	118.1 [3000]

2.6 Sound pressure level

The noise emission level to DIN 45635 (L_{pAF}) is:

DC-Pro 1 to 32 ft/min (8 m/min) 65⁺² dB(A)

DC-Pro 2 to 64 ft/min (16 m/min) 65⁺² dB(A)

DC-Pro 5 to 48 ft/min (12 m/min) 69⁺² dB(A)

DC-Pro 10 to 48 ft/min (12 m/min) 69⁺² dB(A)

DC-Pro 20 to 48 ft/min (12 m/min) 69⁺² dB(A)

at a distance of 3.28 ft (1 m) from the chain hoist.

These noise emission levels were measured under maximum load.

Structural influences such as

- transmission of noise via steel structures,
- reflection of noise from walls, etc.

were not allowed for in the above measurements.

2.7 Transportation and storage

Demag chain hoists, the accessories and the trolleys are shipped in cardboard packaging.

Store chain hoists and accessories in a dry place.

Temperature range for transportation and storage -13°F to 131°F (-25°C to +55°C).

2.8 Surface protection and painting

As standard, the chain hoist is supplied with corrosion protection (powder coating/ paint finish) in the following colours:

Chain hoist	RAL 5009	Azure blue
Hook assembly	RAL 1007	Chrome yellow
Load hook and suspension bracket	RAL 9005	Jet black
Trolley	RAL 5009	Azure blue

Other paint coats as well as special paints are possible.

2.9 Operating conditions

The chain hoist and the trolley can be operated at:

Ambient temperature: 14°F to 104°F (-10°C to +40°C),

Humidity: max. 80 % relative humidity,

Height: up to 3281 ft (1000 m) above sea level,

Type of enclosure: IP55,

Electromagnetic compatibility: Immunity for industrial environments,

Emission standard for residential, commercial and light-industrial business environments



Demag chain hoists operating outdoors should be provided with a cover for protection against the weather or chain hoists, trolleys and travel drives should be kept under shelter if they are not used.

Deviations from the operating conditions may be agreed with the manufacturer in individual cases.

3 Description

3.1 Design

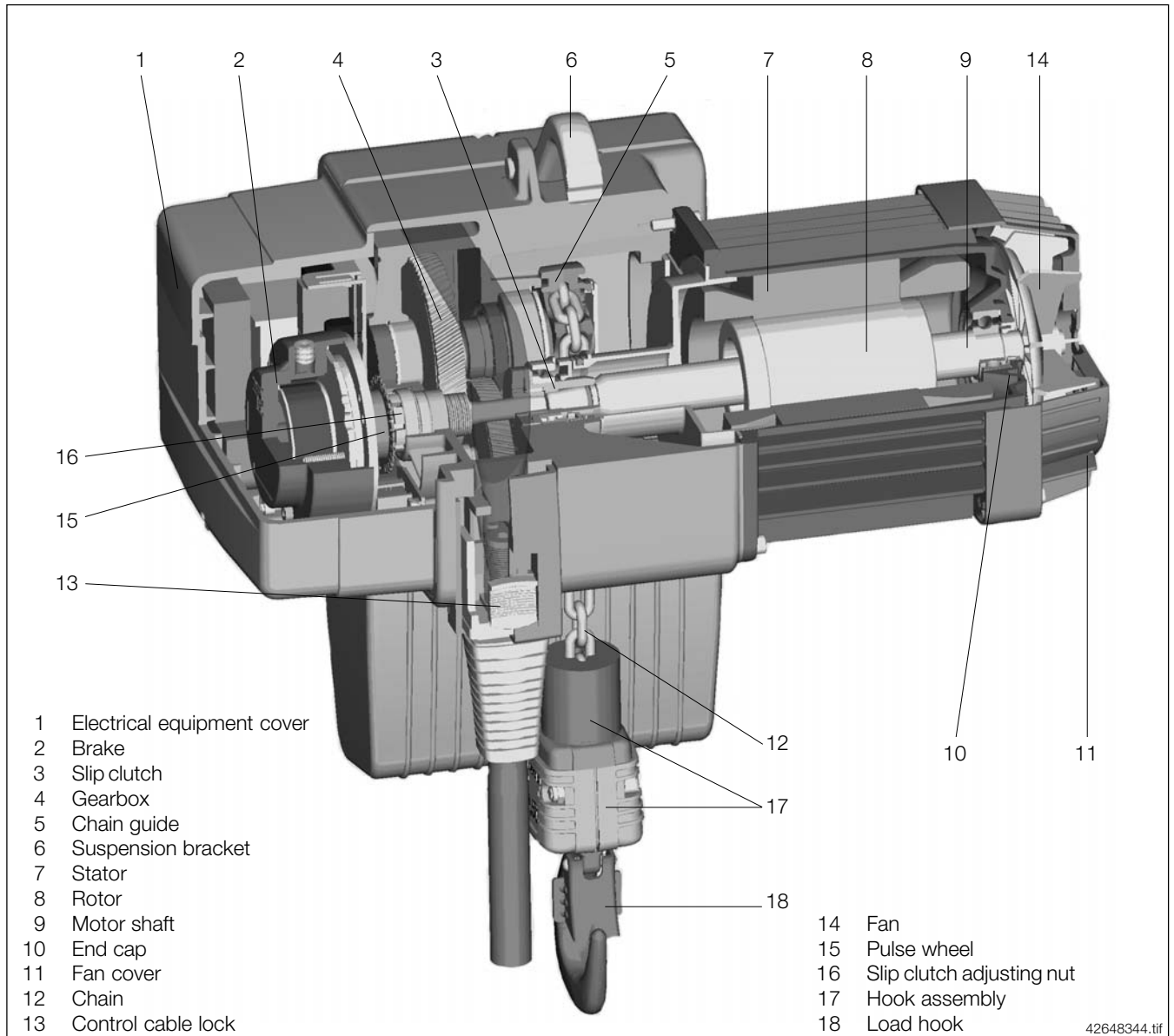

3.2 Drive

A robust pole-changing AC asynchronous motor is used as hoist motor. The brake is arranged on the load side so that after tripping of the slipping clutch, a slipping load is braked. The brake is released electrically. Pressure springs ensure automatic brake application when the motor current is switched off or in the event of a power failure. The control system automatically switches the brake in the upper and lower end positions of the lifting path, when the slipping clutch is tripped and in the event of error statuses. From the fast speed, the hoist drive is decelerated by means of a speed-controlled electrical brake. The brake requires no maintenance thanks to electrical braking from the 8-pole winding.

3.3 Gearing and slip clutch

The slip clutch is arranged between the motor shaft and pinion shaft. It performs the function of the emergency limit stop device for the highest and lowest hook position and protects the Demag chain hoist against overloads. The additional electrical limit switches for the highest and lowest hook positions prevent the slip clutch from use as an emergency limit stop device resulting from bottoming the hook on the hoist during normal operation. The slip clutch also fulfils the EC directive requirements regarding a load control device starting with a capacity of 2200 lbs (1000 kg).

The brake arranged on the load side prevents load sinking when the unit is at rest. Monitoring of the slip clutch and automatic cut-out of the drive in the event of slip increase the service life and protect the slip clutch against overload and incorrect use. Therefore, the slip clutch requires no maintenance.

3.4 Chain drive

The special Demag chain is of high strength ageing-resistant material with a high degree of surface hardening, galvanised with additional surface treatment. The dimension tolerances of this chain have been precisely adapted to the chain drive. We therefore urgently recommend that the Demag special chain be used to ensure safe operation. The maximum service life of the chain can only be reached, if the specified regular lubrications are appropriately carried out. When a chain is replaced, the entire chain drive is always replaced. For this purpose a chain set that can be easily replaced is available. The chain set offers the following benefits:

- the optimum duration of service is ensured for the chain;
- reliable decision for replacing the individual chain drive components;
- reduction in service costs by replacement in one installation process; it is not necessary to dismantle the motor or the gearbox.

3.5 Housing

The housing of the chain hoist is of strong light-weight die-cast aluminium. The fan cover on the motor, the service cover and the movable chain collector box are of particularly impact-resistant plastic material.

3.6 Electrical equipment

The chain hoist is provided with a 24-V contactor control system. The contactor control system is supplemented by an electronic system with program-controlled functions. This electronic system detects the control commands that are tripped by the operator with the control pendant. Permissible control commands generate switching commands for the contactors to control the hoist motor. The electronic system monitors the control sequence specified by the operator based on the speed feedback from the drive shaft, the limit switch contacts and, if applicable, from the thermal contacts of the motor. In the event of any discrepancies, the chain hoist is automatically brought to a safe status and warning and error messages are generated. The forced disconnected emergency stop contact of the control pendant immediately opens the circuit for the contactor supply so that the motor is de-energized and the brake is applied. As standard, the control system features the following characteristics:

- Limit switches for lifting and lowering;
- Plug-type connections for control pendant, power supply, motor connection, brake, limit switches;
- Connection for a trolley control system;
- 7-segment display for operating status, error messages and operating hours;
- Infra-red interface for wireless transmission of servicing data.
- Interchangeable, socket-mounted contactor for DC-Pro 10 and DC-Pro 20.

For manual control, Demag control pendants are connected via plug-in connectors. For Demag DC chain hoists without electric trolleys, the compact DSC optimised for this application is used, the DSE-C for applications with electric trolleys.

3.7 Central service enclosure

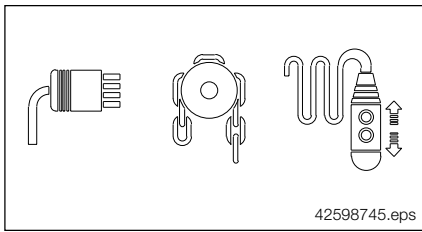

All important servicing work can be carried out at a central point, the service enclosure. The relevant connectors for power supply, control pendant and travel drive are arranged under the impact-resistant plastic cover. From this point, the chain is also lubricated.

In addition, any not required control cable length is accommodated under the cover. The plastic cover also provides mechanical protection for the components fitted under it. The functions are described by pictograms fitted on the outside of the service cover.

3.8 Control pendant height adjustment

The control cable is protected by a flexible easily bent strain relief hose. It can be specifically adapted in its suspension height to the requirements at the workplace at any time by means of an adjusting mechanism. To do this, it is not necessary to cut the cable conductors or to shorten the strain relief hose. The not required control cable is accommodated under the service cover. The strain relief hose is fixed at the selected suspension height by means of a self-locking clamping mechanism. The control pendant can be adjusted to a different suspension height by unlocking the clamping mechanism.

The strain relief hose for the control pendant consists of an abrasion-resistant fabric hose with flame-protection impregnation.

In the gripping range, a filler material is inserted in the lower 0,8 m of the strain relief hose for improved ergonomics.

3.9 Control pendant

For manual cable control of the chain hoist, the DSC control pendants (lifting/lowering) or the DSE-C (2 to 3 axes) are to be used. Both control pendants feature the same plug-in connection for the control cable. The control cable and the control pendant are connected by means of a bayonet lock.

The shock and impact-resistant DSC and DSE-C casings of high quality thermoplastic are resistant to fuels, salt water, greases, oils and alkaline solutions, type of enclosure IP 65.

Strong mineral (e.g. hydrochloric or sulphuric) acids may, however, corrode pendant switch casings. To avoid this, they must be replaced in good time.

3.10 DCM Manulift with quick-release coupling

The DCM Manulift variant is fitted with the DSM-C control unit.

Mechanical interlocking of the switching elements prevents movement in opposite directions being switched on simultaneously. The shock and impact-resistant housing of high quality thermoplastic is resistant to fuels, salt water, fats, oils and alkaline solutions.

Type of enclosure IP 65.

The main operating elements and controls are:

The spade handle for guiding, positioning and moving the load horizontally. The R/H and L/H rockers for lifting and lowering which both have the same functions. The handle can thus conveniently be gripped with the left or right hand. The rocker is actuated with the thumb without having to open the fist.

The lifting and lowering movements are marked by arrows and have two speeds:

- Slow lifting or lowering is obtained by pressing the rocker until a stop is felt.
- Fast lifting or lowering is obtained by pressing the rocker down completely.

The rigid link between the DSM-C control unit and the load handling accessory provides a direct connection between the operator's hand and the load.

The integrated quick-release coupling allows the accessory to be removed and replaced within seconds when no load is applied.

Power is supplied to the DSM-C control unit through a wear-resistant helical rubber cable.

As standard

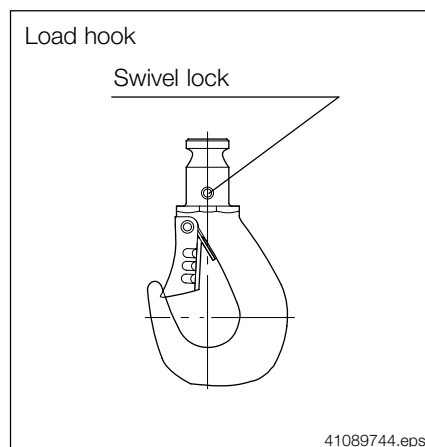

The swivel lock of the load handling attachment must not be removed.

Accessories

Gripping hook

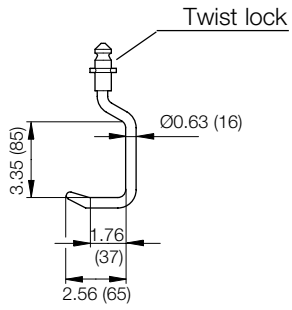

41113144.eps

Pantograph-type tongs

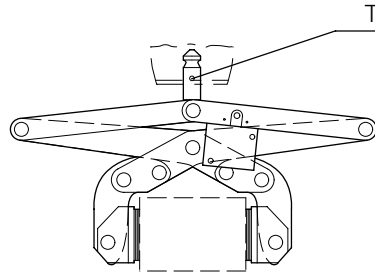

41113244.eps

Belt sling

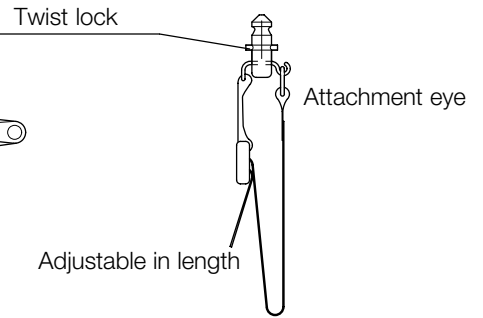

41113444.eps

Coupling pin

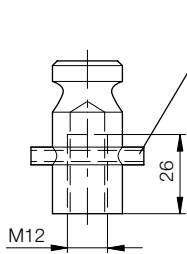

41113044.eps

Pantograph-type tongs

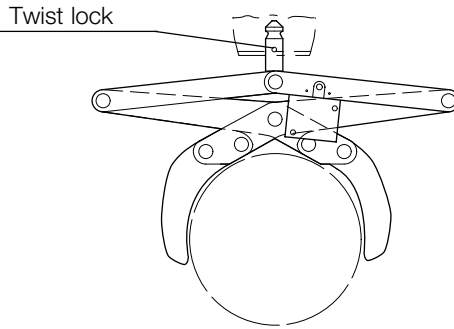

41113344.eps

Belt sling width 1.77 in (45 mm)
max. dia. to be gripped 16.94 in (430 mm)

units = in (mm)

3.11 Suspension

DC-Pro 1 to DC-Pro 20 chain hoists are supplied with a short and an extended suspension bracket as standard. A longer suspension bracket is enclosed with every chain hoist. It is decided on site which of the two suspension brackets is to be used. The suspension bracket facilitates installation. The chain hoist can be directly suspended in the trolley. The suspension bracket is also suitable for quickly changing the installation site since it performs the function of the suspension hook. It is not necessary to dismantle existing trolleys.

Chain hoists with short or long suspension brackets can be combined with the following trolleys:

<p>DC-Pro 1-5 Fitted as standard, suitable for:</p> <ul style="list-style-type: none">• KBK 100, KBK I, KBK II• CF 5• U 11• RU 3, from flange width 60 mm	<p>Included in cardboard box (conversion), suitable for:</p> <ul style="list-style-type: none">• KBK III• KBK articulated frame• KBK load bar• KBK crab frame• RU 6• RU 11, EU 11
--	---

42591546.eps

DC-Pro 10
DC-Pro 20 up to 2200 lbs
(1000 kg)
Long suspension bracket,
fitted as standard,

used on trolley

- U 11
- articulated frame KBK II
- load bar KBK II and III
- crab frame II
- KBK III

also possible:

- RU/EU 11 / 22 / 36
- U 22
- KBK II 1100 lbs (500 kg)
- articulated frame KBK III
- crab frame KBK I and III

Short suspension bracket,
included in cardboard box
(conversion),

used on trolley

- U 11

also possible:

- RU/EU 11 and 22
- U 22
- KBK II 1100 lbs (500 kg)

DC-Pro 20
> 2200 lbs (1000 kg)

Long suspension bracket,
fitted as standard,

used on trolley

- U 22
- articulated frame KBK III
- load bar KBK III
- crab frame KBK

also possible:

- RU/EU 22
- RU/EU 36

Short suspension bracket,
included in cardboard box
(conversion),

used on trolley

- U 22

also possible:

- RU/EU 22

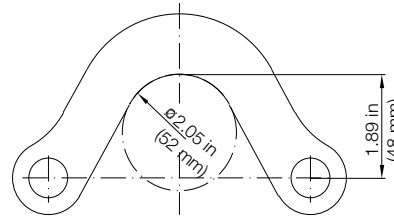
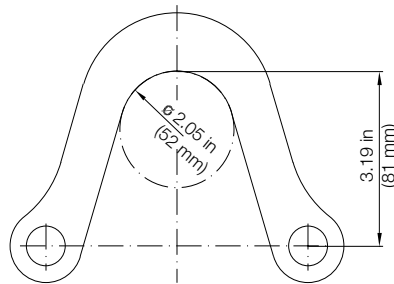

42591547.eps



Ensure spacer elements are correctly seated when replacing the suspension bracket (1/1 or 2/1 reeving lettering on the gearbox housing).

3.12 Trolley



The load capacity of the Demag chain hoist must not exceed the load capacity of the trolley.

I beam tracks

The use of I beams with parallel or sloping flanges Wor S is possible.

CF and U 11 trolleys are suitable for extremely small curve radii.

The track radius should be as large as possible in order to ensure good travel characteristics.

I beam tracks should be bent with the utmost care in order to obtain a clean, regular curve.

Hoist travel on I beams must in no way be obstructed by protruding suspension bolts, screw heads, butt straps, clamping plates, etc.

Resilient buffers should be mounted at travel wheel axle level at the ends of tracks in order to prevent the trolley from derailing (e.g. Demag clamp-fitted buffers).



For further information on the trolleys and the power supply, see:

CF 5 trolley	203 568 44	714 IS 845
U 11/ U22 trolley	203 569 44	714 IS 845
E 11/ E 22 electric travel drive	900 456 49	720 IS 817
KBK 0 + 25 trailing cable power supply	202 482 44	714 IS 963
KBK 0 + 25 power supply lines	202 386 44	714 IS 963
Clamp-fitted buffers	203 313 44	714 IS 888

Trolley	CF 5	U 11	U 22
Capacity lb [kg]	110 [500]	2495 [1100]	4850 [2200]
Flange width in [mm]	2.0-3.6 [50-91]	2.3-7.8 [58-200], 7.9-12.2 [201-310]	3.2-7.9 [82-200], 7.9-12.2 [201-310]

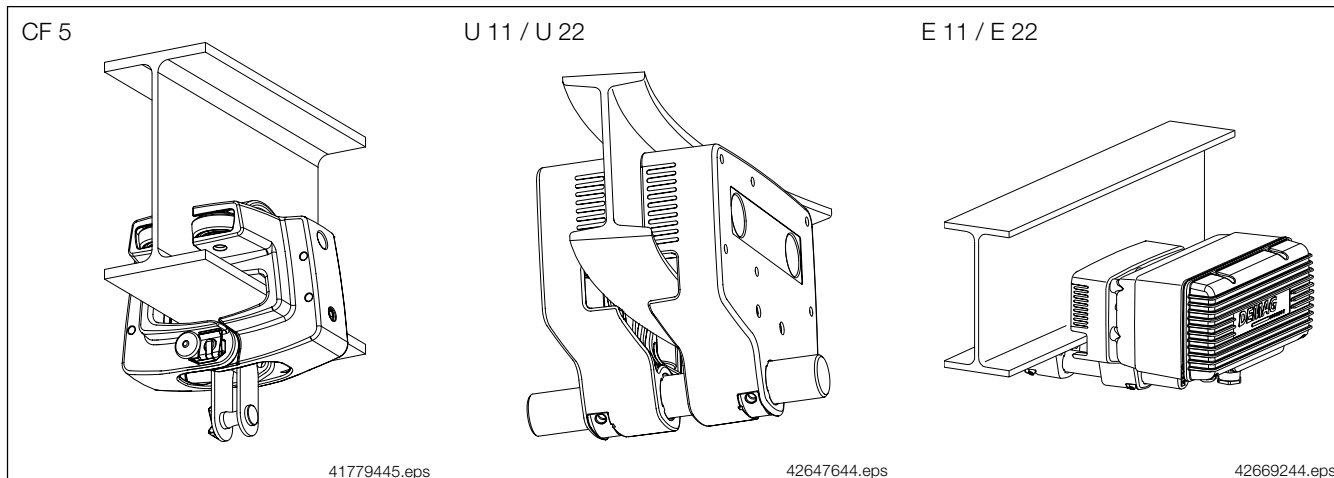

KBK track

When selecting a track, we suggest you specify our KBK crane construction kit track section of special design. They feature in particular quiet running characteristics, a low rolling resistance and a low deadweight. The cold-rolled track sections feature a smooth running surface and offer the advantage of simple power supply by means of trailing cables or integrated conductor lines.

Ready-made curved sections are available for our special track.

Any obstruction by protruding suspension bolts, screw heads, butt straps, clamping plates, etc. can be avoided by using our special track section.



For further information on the trolleys and the power supply, see:

KBK classic (steel, powder-coated)	900 375 49	714 IS 152
KBK Aluline (anodized)	900 337 49	714 IS 152

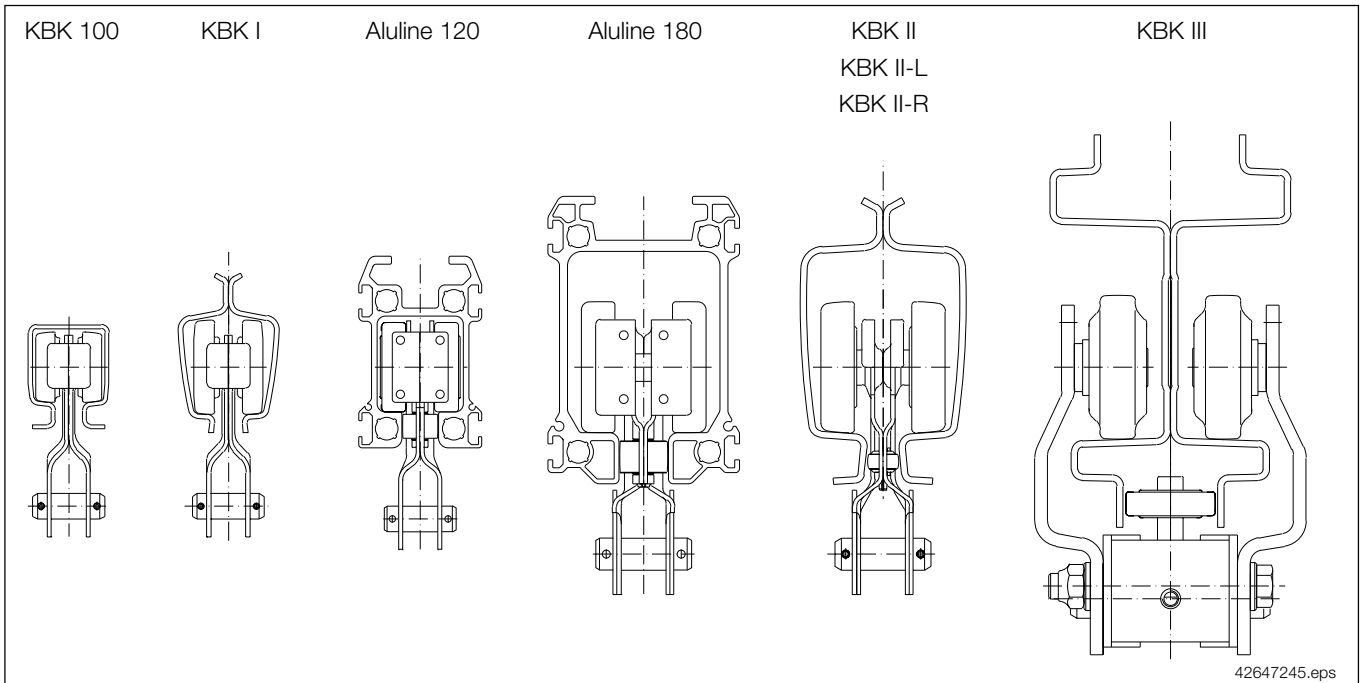

42647245.eps

KBK RF 125

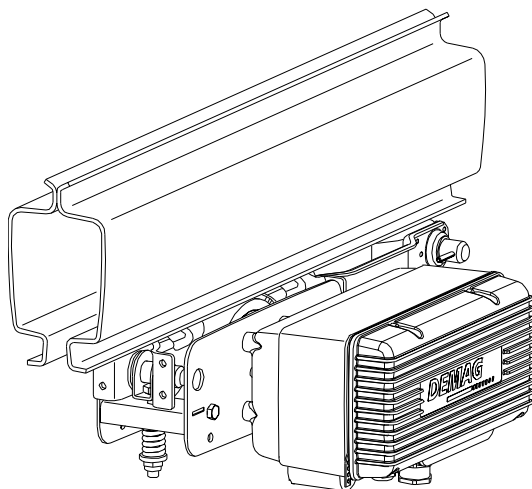

42669144.eps

4 Installation and putting into operation

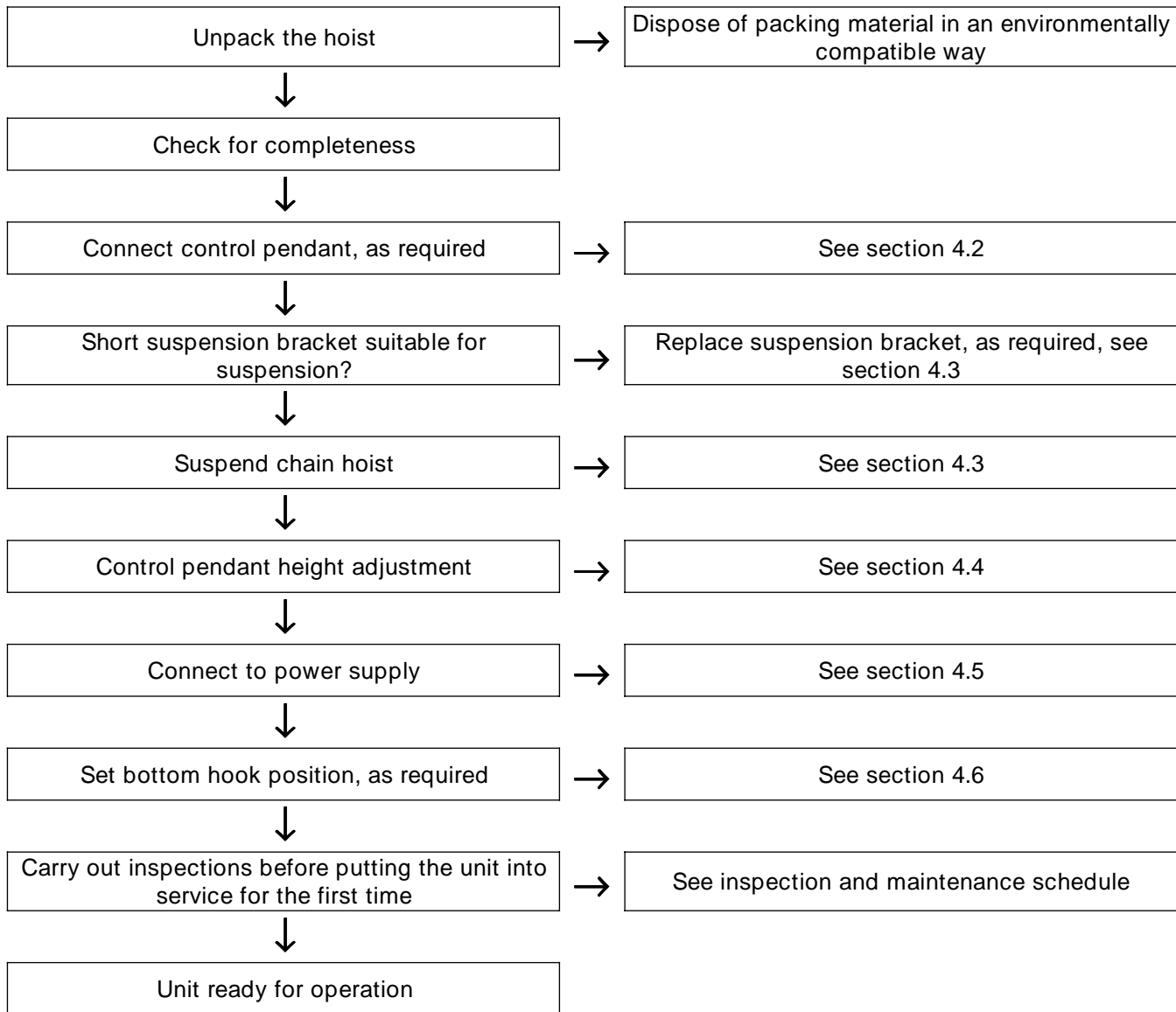

4.1 General



Electrical equipment

Work on electrical equipment may only be carried out by a specialist or trained personnel, see also section 1 Safety instructions.

Each Demag chain hoist is provided with a wiring diagram.

The wiring of the Demag chain hoist complies in all respects with current DIN VDE and accident prevention regulations. Unauthorized intervention and modifications result in eliminating compliance with these regulations.



The switchgear is subject to wear during operation of the chain hoist. Its service life has been rated for the specified loading group. In the case of extreme switching frequencies, premature wear is possible.



Instructions relating to safety at work

All fitting and assembly work must be completed in accordance with the operating instructions and the hoist chain must be greased.

Operation with defective or damaged chains results in a high risk of accident for persons and the chain hoist and is therefore prohibited.

Any change or modification which prejudices safety must be reported to the nearest person responsible immediately. Elimination of faults may only be carried out by experienced technicians.

4.2 Connecting the control pendant

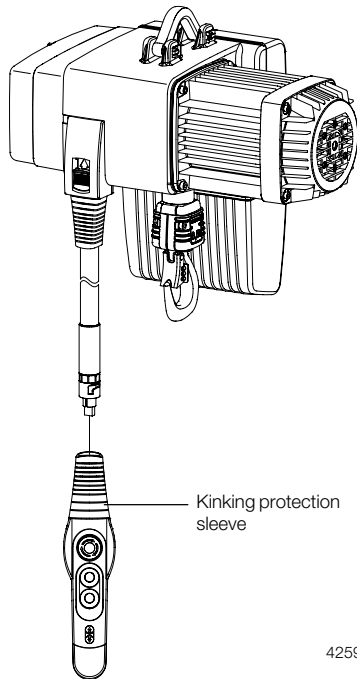

42596044.eps

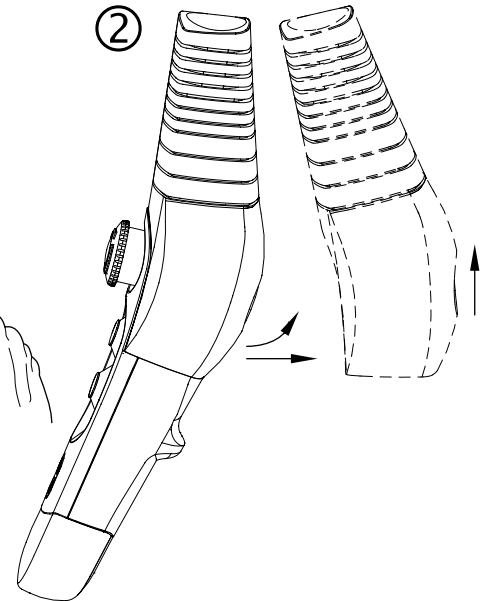
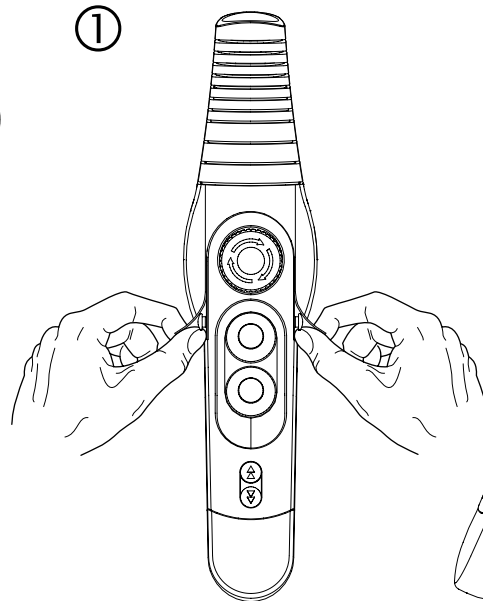

42596144.eps

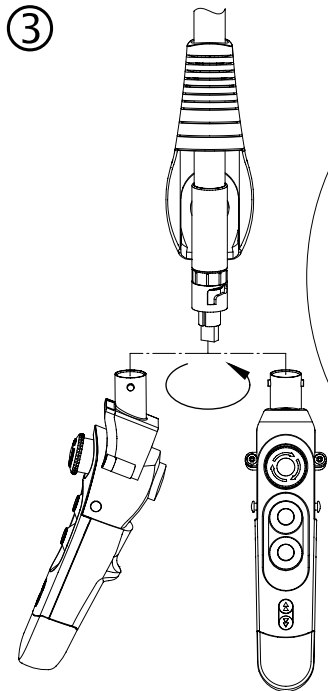

42596244.eps

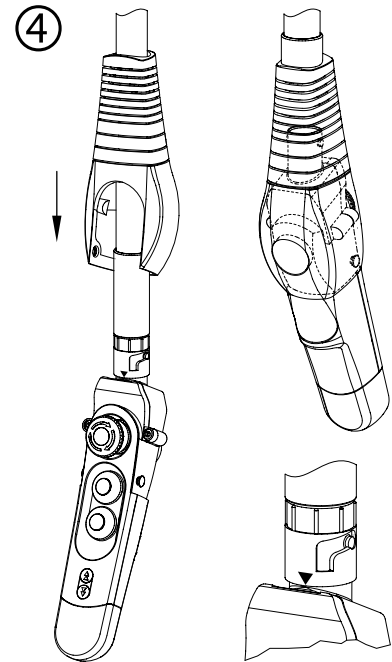
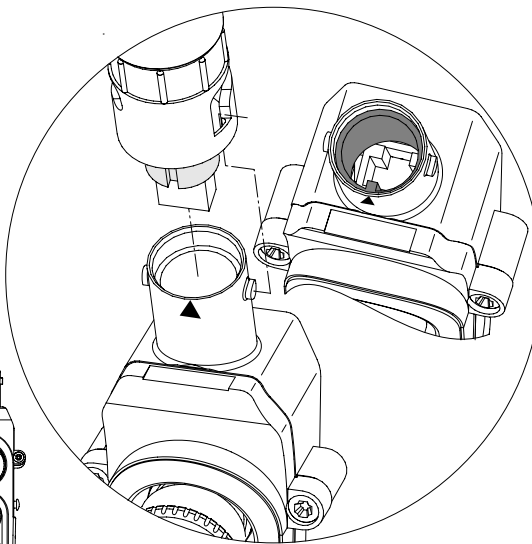

42596344.eps

The control pendant is of plug-in design. Connect the DSC control pendant with the control cable and lock the connection with the bayonet lock.

1. Lift the kinking protection sleeve on the control pendant off the two pins.
2. Then pull the kinking protection sleeve from the control pendant.

3. Slide the kinking protection sleeve onto the control pendant. Plug the control cable into the control pendant and turn the bayonet lock until it is locked. Ensure that
 - the groove of the connector holder matches the swivel lock in the control pendant enclosure and
 - that the two pins on the control pendant enclosure match the bayonet lock.

4. Slide the kinking protection sleeve over the control pendant again. Pay attention to the positioning help. Press the kinking protection sleeve firmly onto the control pendant.

4.3 Suspending the chain hoist

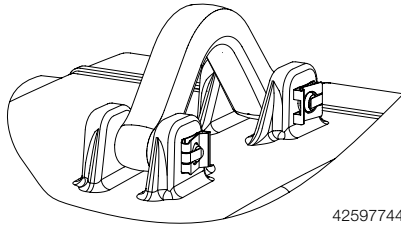

The chain hoist is delivered with the short suspension bracket completely fitted to the chain hoist. Remove the retaining clip and pin on one side. Suspend the suspension bracket in the trolley. Slide the pin through the suspension and the suspension bracket, secure with the retaining clip again.

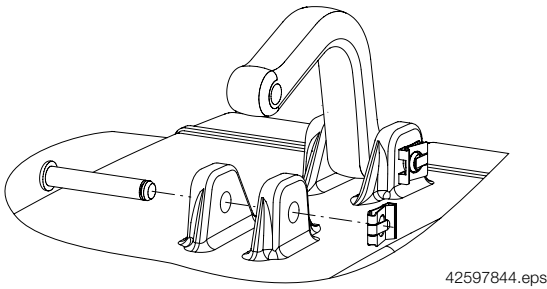

Do not travel the chain hoist or leave it unsupervised when the suspension bracket is open.

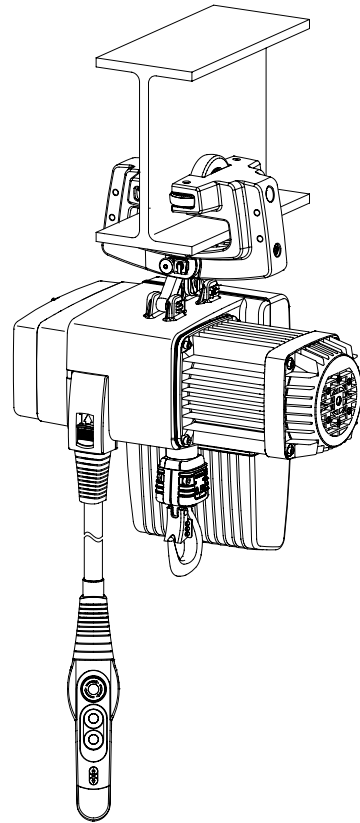
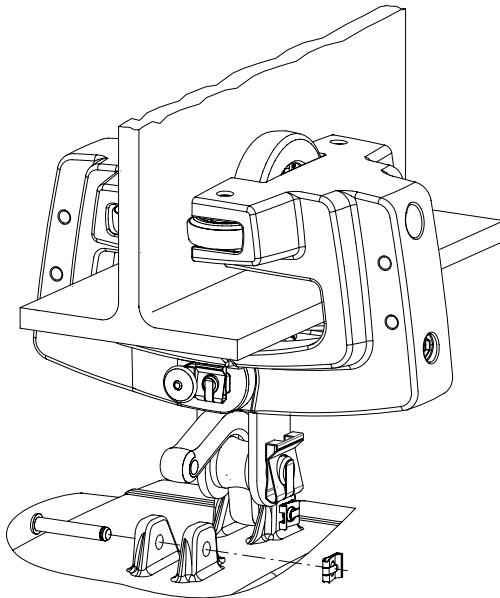

4.4 Control pendant height adjustment

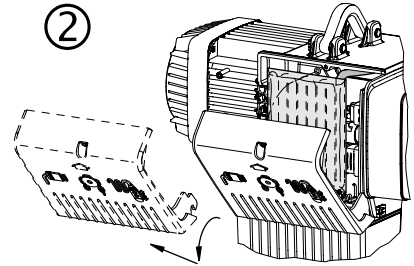
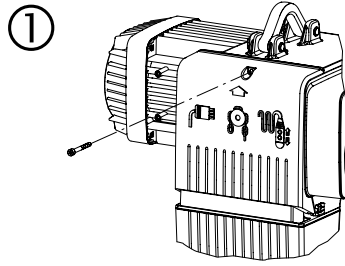
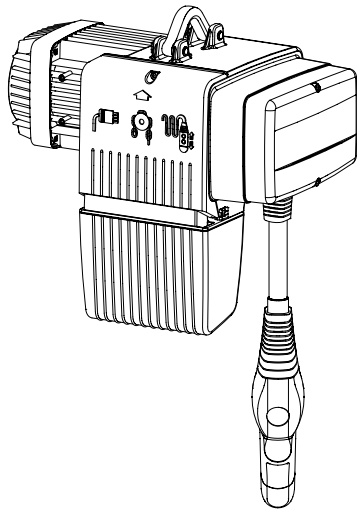

1. Undo the screws of the service cover.
2. Open and disengage the service cover.
3. Remove and open the bag with the control cable.
4. Take the control cable out of the bag.
5. Push the operating button of the control cable lock upwards and hold it.
At the same time, pull the control cable until the correct height has been reached for the control pendant.
6. If the position is too low, pull on the control cable hose hanging behind the service cover.
Slide the operating button of the control cable lock downwards and fix the lock by a short, strong pull on the control cable.
7. Lay the remaining control cable in loops and store it in the bag.
The bag must be behind the edge of the chain collector box.
Close the service cover.

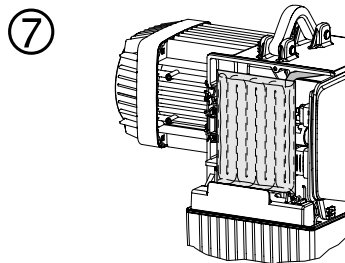
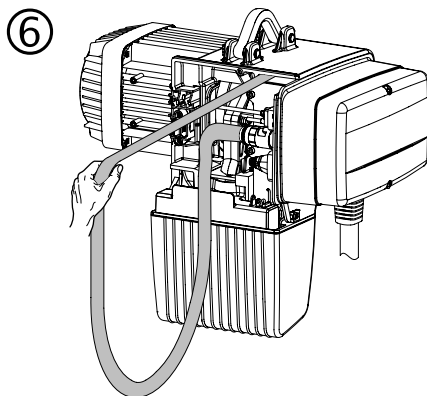
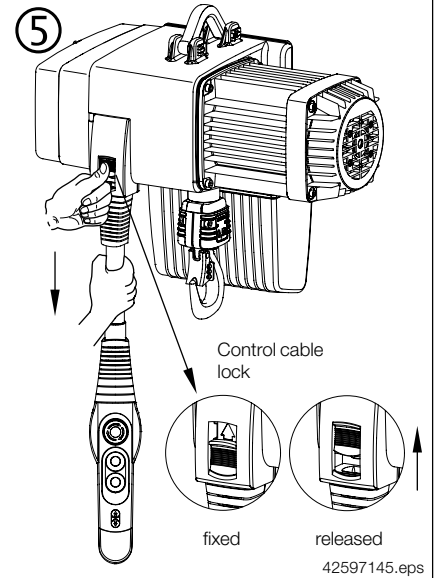
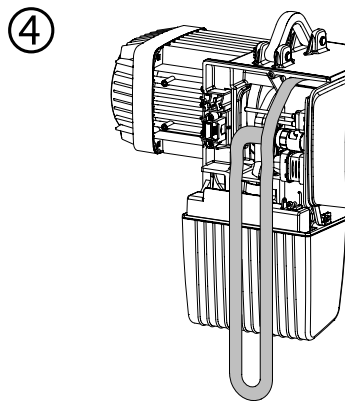
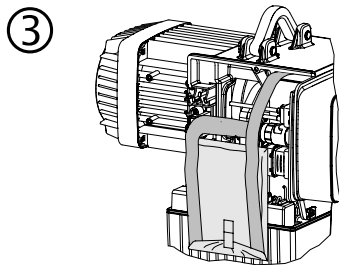

4.5 Mains connection

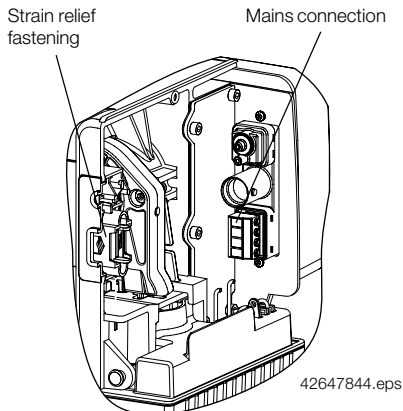
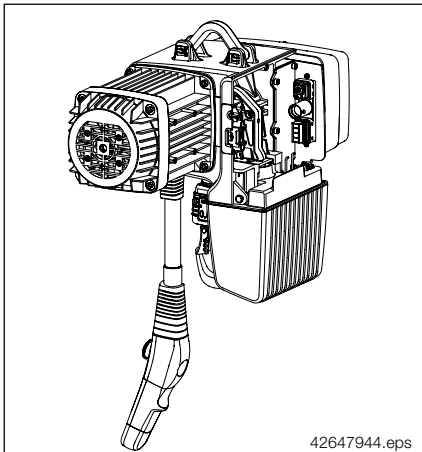

DC-Pro 1 to DC-Pro 5 strain relief fastening
Recess for
Flat cable

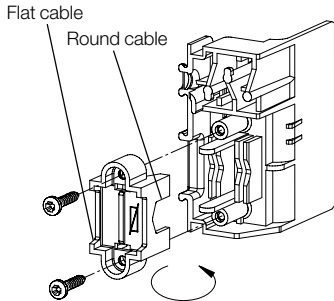

Flat cable

Round cable

42598844.eps

DC-Pro 10 and DC-Pro 20 strain relief fastening

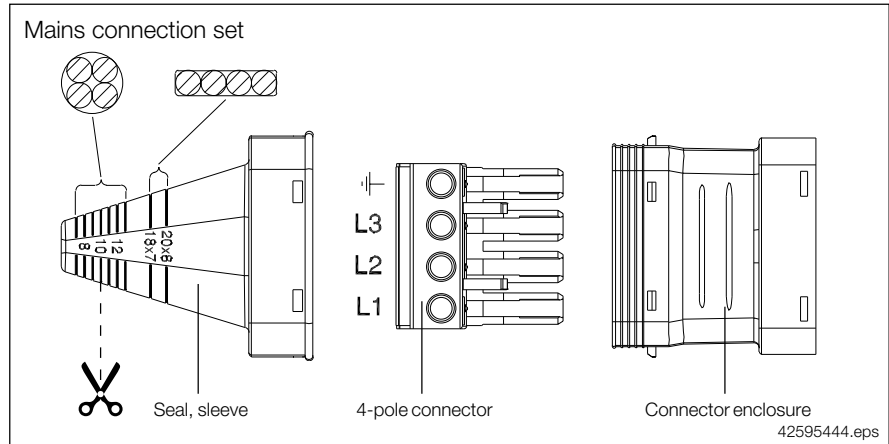
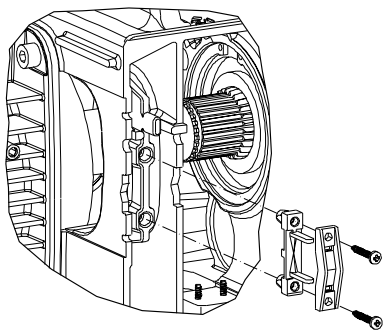

To connect the chain hoist to the power supply, the mains connection cable, the mains connection fuse links and the devices for disconnecting and switching the powerfeed must be available on site. For power supply, a 4-lead cable with an earth lead (PE), which complies with the table in section 2.4, is required.

Please note that the length of the supply cable specified for a given cross section must not be exceeded in order to avoid excessive voltage drop and malfunctions during start-up of the motor caused by undervoltage.

- First check whether the voltage and frequency specified on the capacity plate match your mains supply. Ensure that the mains connection cable is at zero voltage and secured against accidental restoration of the power supply.
- Remove the service cover to connect the supply cable.
- Use the mains connection set included in the delivery to produce the plug-in connection for the mains connection cable.
- Cut the sleeve to suit the geometry of the mains cable.
- For a round cable in the marking area of 7 to 13, for a flat cable in the marking area of 18 x 7 to 20 x 8. Cable cross sections 4 x 1.5² or 4 x 2.5² have been taken into account.
- Slide the sleeve onto the mains cable. Make sure the sleeve tightly encloses the cable to comply with the type of enclosure.
- Connect the mains cable on the connector to terminals L1, L2, L3 and to the PE. If required, use the wire end sleeves included in the delivery.
- Slide the connector into the enclosure until it latches and close the enclosure with the sleeve.
- Then place the connector into the control system until the enclosure latches with the card bracket.
- Finally, insert the mains cable into the union on the enclosure and fix it with the strain relief clamp. Depending on the cable type (flat or round cable), the strain relief clamp must be turned to suit the cable contour for DC-Pro 1 to 5 units.



All enclosure parts must be safely latched to ensure appropriate sealing!

The mains connector must never be disconnected under load.



Checking the direction of movement

To check whether all phases are correctly connected, the chain hoist must be switched. Switch on the power supply, unlock the emergency stop and actuate the “**Lifting**” pushbutton on the control pendant. The load hook must now move upwards.



If the direction is not correct, leads L2 and L3 of the supply cable should be changed over at the mains connection. (Switch off the mains supply before changing over the leads!)

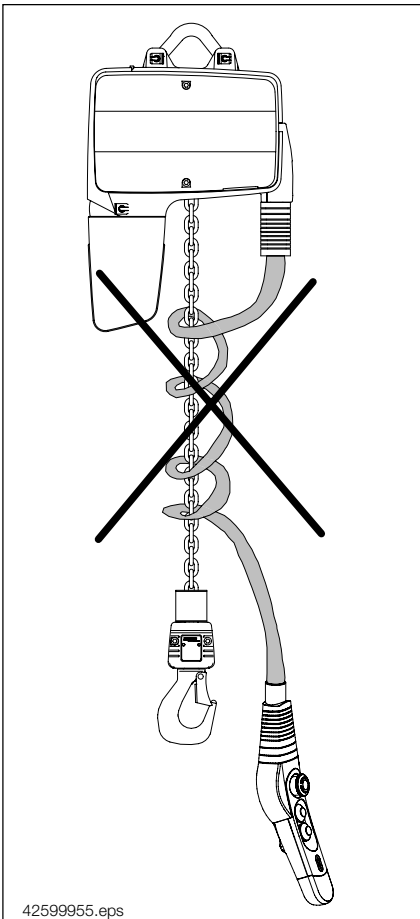

Handling the control cable

Do not allow the control cable to be wound around the chain when lifting motions are performed.

4.6 Setting the bottom hook position

For determining the hook path / lifting height, it must be taken into account that in the bottom hook position the hook assembly rests on the floor.

As standard, the chain hoists are provided with a hook path of 16 ft (5 m) or 26 ft (8 m).

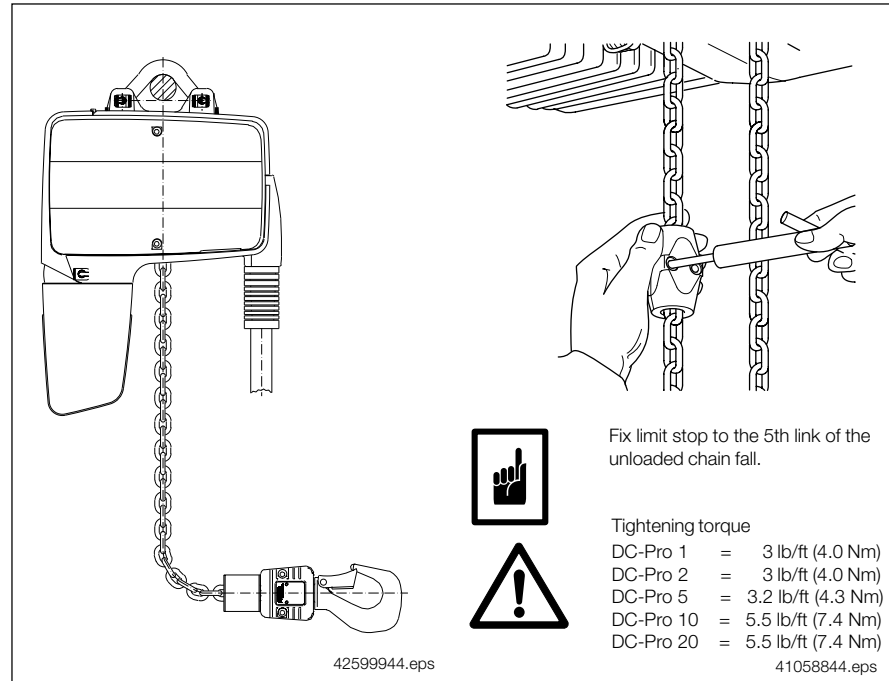

To reduce the hook path, proceed as follows:

1. Move the hook as shown in the figure.
2. Stop the chain hoist by actuating the emergency stop button or the mains connection switch and secure it against switching on again.
3. Dismantle the chain collector box. See section 7.3.
4. Loosen the limit stop on the free chain end.
5. Slide the buffer in front of the guide plate on the chain.
6. Fix the limit stop directly behind the buffer, the buffer plate must be positioned between the buffer and the limit stop. The unloaded chain fall behind the limit stop must have at least 5 chain links.
7. Place the chain into the collector box and refit to the chain hoist.
8. Switch on the chain hoist and check the setting of the bottom hook position by moving the hook and run the hook path setting once through its entire length.

5 Taking the unit out of service at the end of the shift/for maintenance

5.1 Emergency stop

Every chain hoist features an emergency-stop device with which all motions can be stopped in the event of a hazard.

The emergency-stop button is arranged in the control pendant.

To actuate the emergency-stop button, press the button until it reaches the end stop. It then locks automatically.

To unlock the actuated emergency-stop button, turn the pushbutton in the direction of the arrows and release.

The emergency-stop device must only be reset after the hazard and its cause have been eliminated.

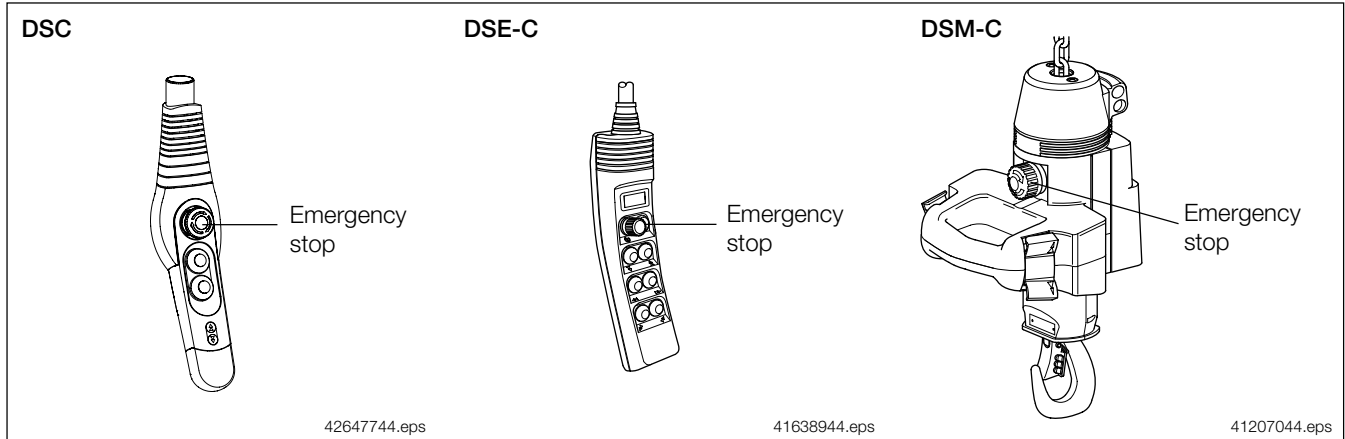

5.2 Taking the unit out of service at the end of the shift

When the work has been completed, position the hook assembly or bottom block outside the travel area. Switch off the power supply at the mains connection or isolating switch.

5.3 Taking the unit out of service for maintenance

Maintenance work on the Demag chain hoist must not commence before the load has been removed and the mains connection switch/isolating switch have been switched off.

The relevant accident prevention regulations and statutory regulations must be observed for operation and maintenance.

Required tests and inspections must be carried out. Adhere to: section 1 Safety instructions and the information in the inspection and maintenance schedule.

6 Inspections/maintenance/general overhaul GO

6.1 Inspection before starting work and during operation

The operator must carry out the inspections in accordance with section 6.5 before starting work. Chain hoists must be taken out of service immediately if any defects relating to operating safety and reliability are detected.

Such defects are e.g.:

- damaged components,
- brake and safety device failure,
- damage to the chain,
- unusual noise in the gearbox, etc.

6.2 Inspection and maintenance schedule



The specified inspection and maintenance intervals (section 6.5) apply to normal chain hoist service conditions. In the course of the annual inspection, all wearing parts are checked.

If routine maintenance reveals that the intervals are too long or too short, they should be adapted to the specific operating conditions.

Only use genuine Demag parts or parts approved by Demag for repairs (see component parts list).

The use of spare parts not approved by Demag renders any liability and guarantee claims void.

6.3 Operating status and error display

The 7-segment display is arranged on the control card under the electrical equipment cover, it can be read through the window (lower side of electrical equipment cover).

The following data can be read:

- Operating hours (section 6.6),
- Operating statuses (section 6.6),
- Warning messages (section 7.9),
- Error statuses (section 7.9).

6.4 General overhaul GO

The theoretical duration of service D (hours at full load h) depends on the group of mechanisms classification of the chain hoist. The actual duration of service is to be determined annually. During the annual inspection by our after-sales service, you may have the actual service life determined.

Upon expiration of 90% of the theoretical duration of service –if the chain hoists are correctly classified after 8 to 10 years –the owner must arrange for a general overhaul GO to be carried out. A general overhaul must be carried out on reaching the end of the theoretical duration of service, at the latest.



During the general overhaul the following parts must be replaced in addition to the checks and work specified in the inspection and maintenance schedule:

- Gearbox housing with joined gearing parts,
- Gear oil and gearbox cover with seal,
- Connecting elements,
- Shaft sealing rings, bearings, plugs.
- Brake.

The small parts (screws, washers, etc.) to be replaced during maintenance and assembly work are not listed separately.

The general overhaul carried out by the manufacturer or an authorized specialist company fulfils the condition for continued operation of the chain hoist.

Thus the relevant accident prevention regulations and the BGV D8 (VBG 8) are complied with.

Further utilization is approved when an expert engineer has entered the conditions for further utilization into the test and inspection booklet. The completion of the general overhaul must be confirmed in the test and inspection booklet.

6.5 Inspection and maintenance schedule

	See section	Before putting into operation	When starting work	During the annual inspection
Check emergency stop		X		X
Check direction of movement	4.5	X		
Check 7-segment display		X	X	
Check chain lubrication (under heavy-duty conditions, the chain must be lubricated more frequently)	7.4	X	X	X
Check operation of lifting and lowering limit switches	7.10	X	X	X
Check cable and casing parts of the control pendant		X	X	X
Check operation of the brake		X	X	X
Check hook and hook safety catch		X	X	X
Check the operating hours to determine the remaining duration of service	6.6			X
Check electrical switchgear and wiring				X
Check operation of the slipping clutch	7.7			X
Check brake wear			Every 10 years ¹⁾	
Check suspension, suspension bracket and securing elements (clip etc.)				X
Check securing screws on hook assembly				X
Check hooks for cracks, deformation and wear				X
Check hook safety catch for deformation				X
Check hook bearing for wear				X
Check chain sprocket, chain guide				X
Check fastening of the chain and the chain collector box				X
Check chain for deformation, damage, cracks, pitting, reduction in the thickness of the links or increase in pitch due to wear, elongation caused by deformation	7.4			X
Check securing elements (clips, screws etc.) for tight fit and corrosion				X
Check and apply or supplement corrosion protection, as required				X
Check electrical enclosure and gearbox for leakages				X
Check trolley, load bar and condition of buffers				X

General overhaul

The general overhaul should coincide with the annual inspection		On reaching the theoretical duration of service
it chain-hoist specific Demag GO set		X

The small parts (screws, washers ...) to be replaced during maintenance and assembly work are not listed separately. The tasks specified in the inspection and maintenance schedule must be carried out during a GO.

¹⁾ DC-Pro 10 and DC-Pro 20 every 5 years

6.6 Display of operating hours / statuses

Operating hours

Display appears after 3 sec without lifting motion (example 123 operating hours)

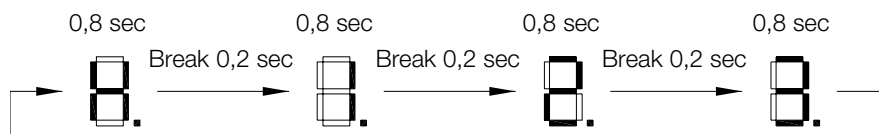

42599844.eps

Operating statuses

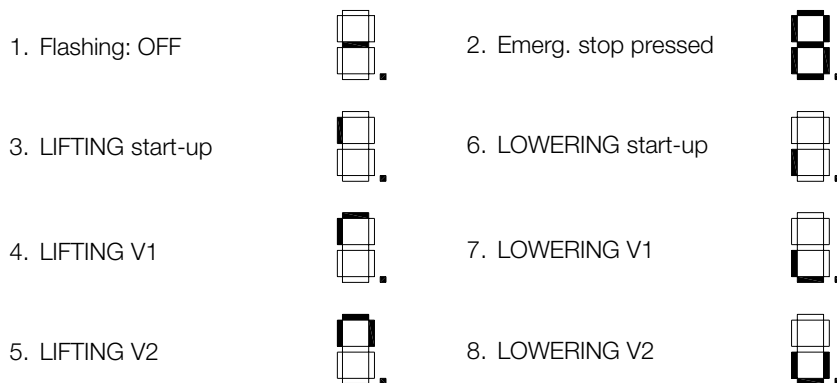

42599745.eps

7 Maintenance

7.1 Replacing the hook

7.1.1 1/1 reeving

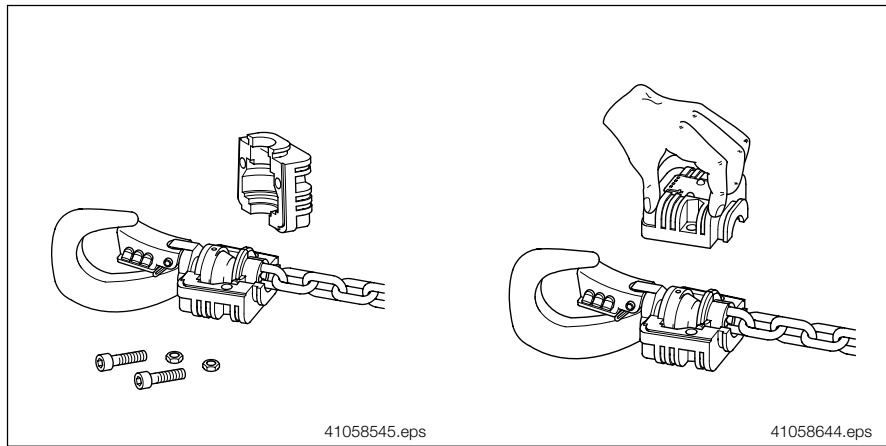
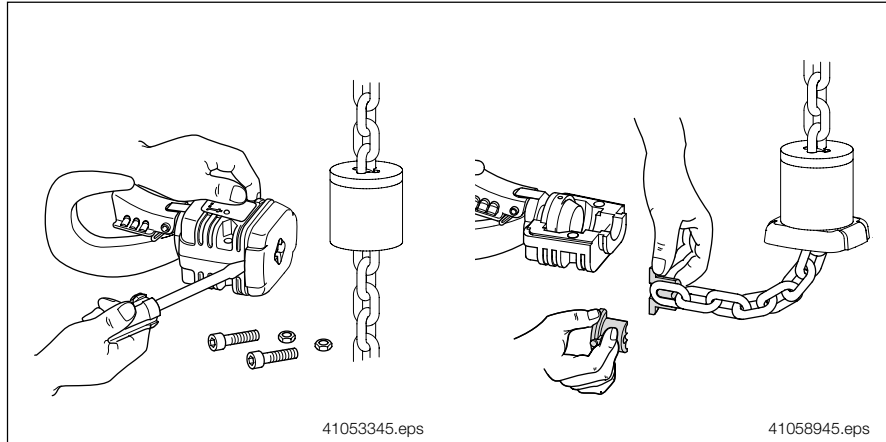

41058746.eps

41058844.eps

! (Warning symbol)

Tightening torque

- DC-Pro 1 = 5.0 lb-ft (6.8 Nm)
- DC-Pro 2 = 5.0 lb-ft (6.8 Nm)
- DC-Pro 5 = 8.5 lb-ft (11.5 Nm)
- DC-Pro 10 = 18.4 lb-ft (25 Nm)
- DC-Pro 20 = 18.4 lb-ft (25 Nm)

! (Warning symbol)

Fix limit stop to the 5th link of the unloaded chain fall.

Tightening torque

- DC-Pro 1 = 3.0 lb-ft (4.0 Nm)
- DC-Pro 2 = 3.0 lb-ft (4.0 Nm)
- DC-Pro 5 = 3.2 lb-ft (4.3 Nm)
- DC-Pro 10 = 5.5 lb-ft (7.4 Nm)
- DC-Pro 20 = 5.5 lb-ft (7.4 Nm)

7.1.2 Replacing the bottom block for 2/1 reeving, DC-Pro 20

Bottom block with external cut-off springs

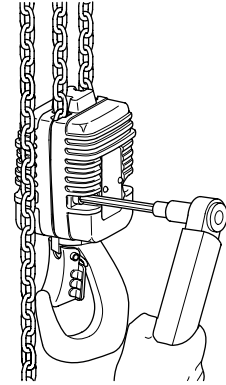
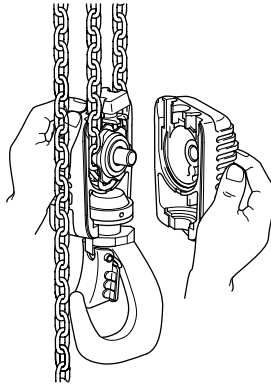

Tightening torque
DC-Pro 20 = 40.6 lb-ft (55 Nm)

41057244.eps

41057344.eps

Bottom block with internal cut-off springs

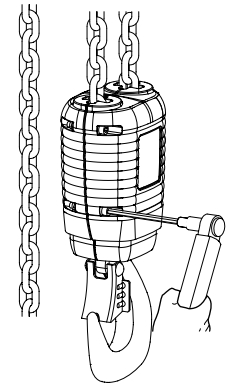
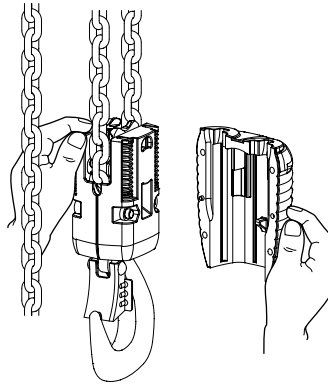

Tightening torque
DC-Pro 20 = 40.6 lb-ft (55 Nm)

42674244.eps

42674544.eps

1. Take the hoist out of service;
2. Disassemble guide halves (four M 6 screws);
3. Disconnect chain from anchorage (see section 7.2)
4. Remove chain from bottom block;
5. Check correct fit of the four cut-off springs in the bottom block halves;
6. Introduce new chain into the bottom block in the same position and orientation (chain must operate without any twist);
7. Fit new guide halves (tightening torque = 6 Nm);
8. Apply load capacity plate;
9. Perform function check (run against limit switches and check against 7-segment display).

7.2 Dismantling the chain set

DC-Pro 1 to 5
Retaining ring

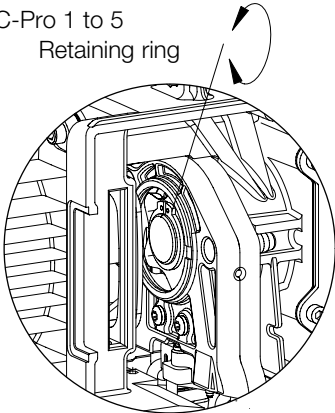

42599155.eps

DC-Pro 10 to 20

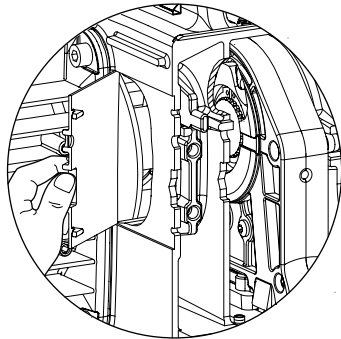

42674144.eps

Fitting the chain anchorage
DC-Pro 20, 2/1 reeving

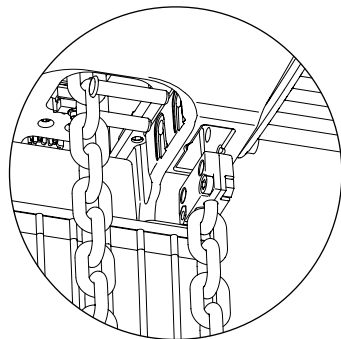
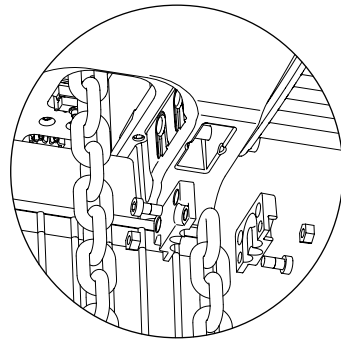

42674044.eps

On reaching the permissible limit of chain wear, the chain set must be replaced (for determining the wear limit of the chain, see section 7.4).

The chain set includes the following parts:

- Chain with standard length or special length,
- Sprocket,
- Chain guide with plate and cap,
- Chain guide plate,
- Buffers for upper and lower hook position,
- Demag chain grease tube,
- Retaining ring,
- Chain anchorage for reeving 2/1.

The chain guide is pre-assembled, the chain is already fitted in the chain guide.

To replace the chain set, proceed as follows:

1. Open and disengage the service cover;
2. Place bag with control cable on chain hoist;
Disconnect the chain hoist from the power supply (mains connection switch);
Pull out and deposit mains cable union with fitted mains cable;
if a travel drive is fitted, remove the connection cable from the strain relief;
3. Loosen cap with a screw driver (lever off);
4. Dismantle and deposit chain collector box (see section 7.3);
5. Dismantle the guide plate;
6. Dismantle the retaining ring using Seeger ring pliers, either use offset or straight pliers (access from the service enclosure or through the opening in the gearbox housing on the side of the motor);
DC-Pro 1 to 5: remove the mains cable union;
DC-Pro 10 to 20: turn the cover of the opening in the gearbox housing to the side.
7. Loosen the chain guide with sprocket from the output shaft; to do this, slide the complete assembly in the direction of the motor until the sprocket is free;
Then remove the worn chain set from the service enclosure.

For fitting the new chain set, proceed accordingly in reverse order. Pay attention to the following:

- Before you slide on the chain sprocket, lubricate the splining of the output shaft with Molykote or similar.
- The stamped burr of the retaining ring must face the motor.
Correct fit of the retaining ring is ensured when it can be easily turned on the output shaft after assembly.
- Fit the hook assembly to the chain end as described in the figures (section 7.1).
- Fit the chain anchorage before bolting the guide plates into position for DC-Pro 20 with 2/1 reeving.
- When fitting the chain, it must be ensured that the chain is introduced in the same position and orientation. The chain must operate without any twist.
- After replacing the chain set, the chain must be lubricated (see section 7.4) and the bottom hook position must be adjusted, as required (see section 4.6).

Fitting the chain anchorage on DC-Pro 20 for 2/1 reeving

- Bolt anchorage halves together (tightening torque = 7.7 lb-ft (10.5 Nm));
- Insert the bolted chain anchorage into the opening of the gearbox housing;
- Fit pins (retained by fitted guide plates).

①

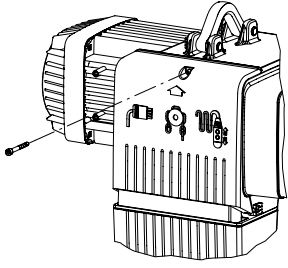

42596644.eps

②

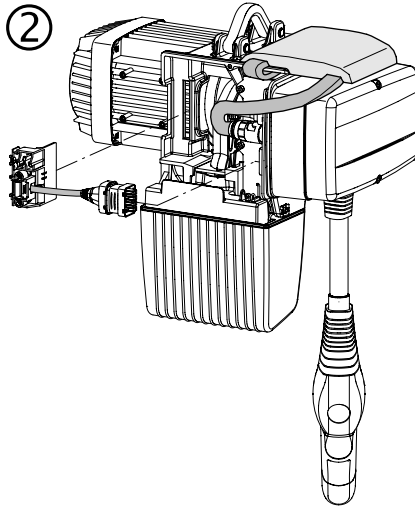

42598144.eps

③

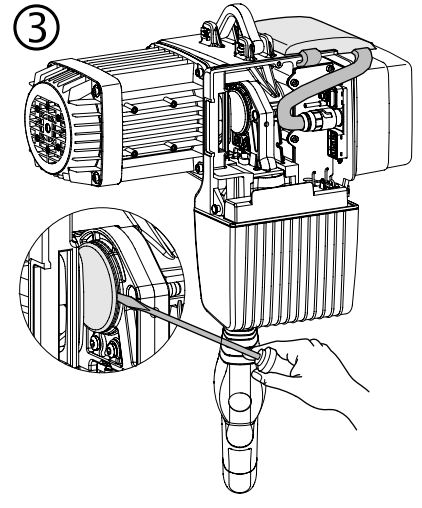

42598344.eps

④

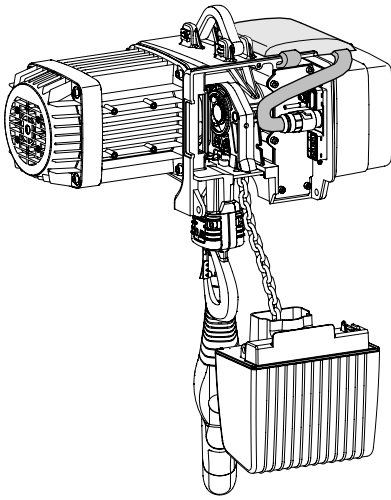

42598944.eps

⑤

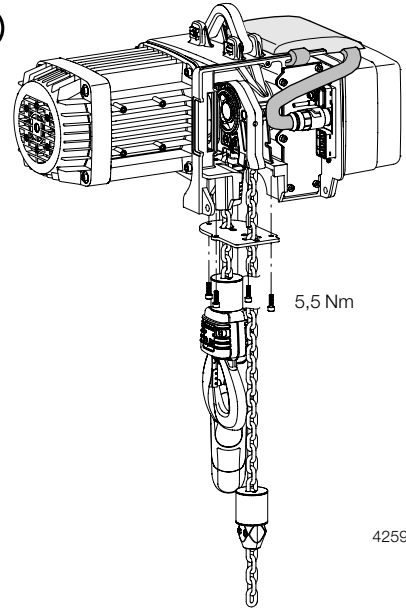

42599144.eps

⑥

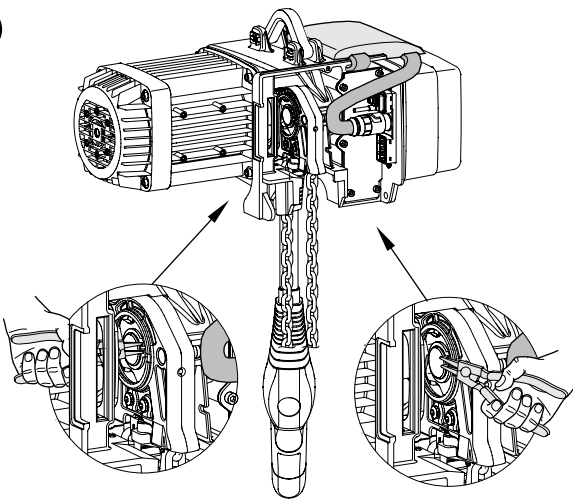

42599244.eps

⑦

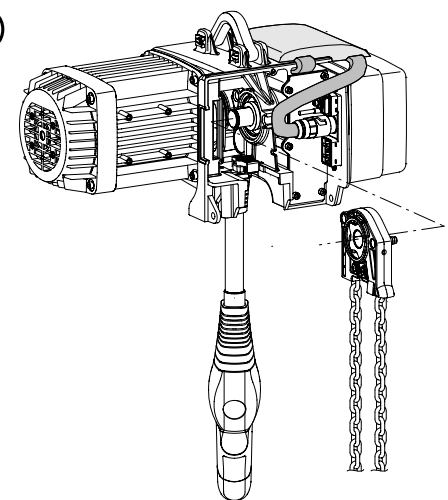

42599344.eps

7.3 Dismantling the chain collector box

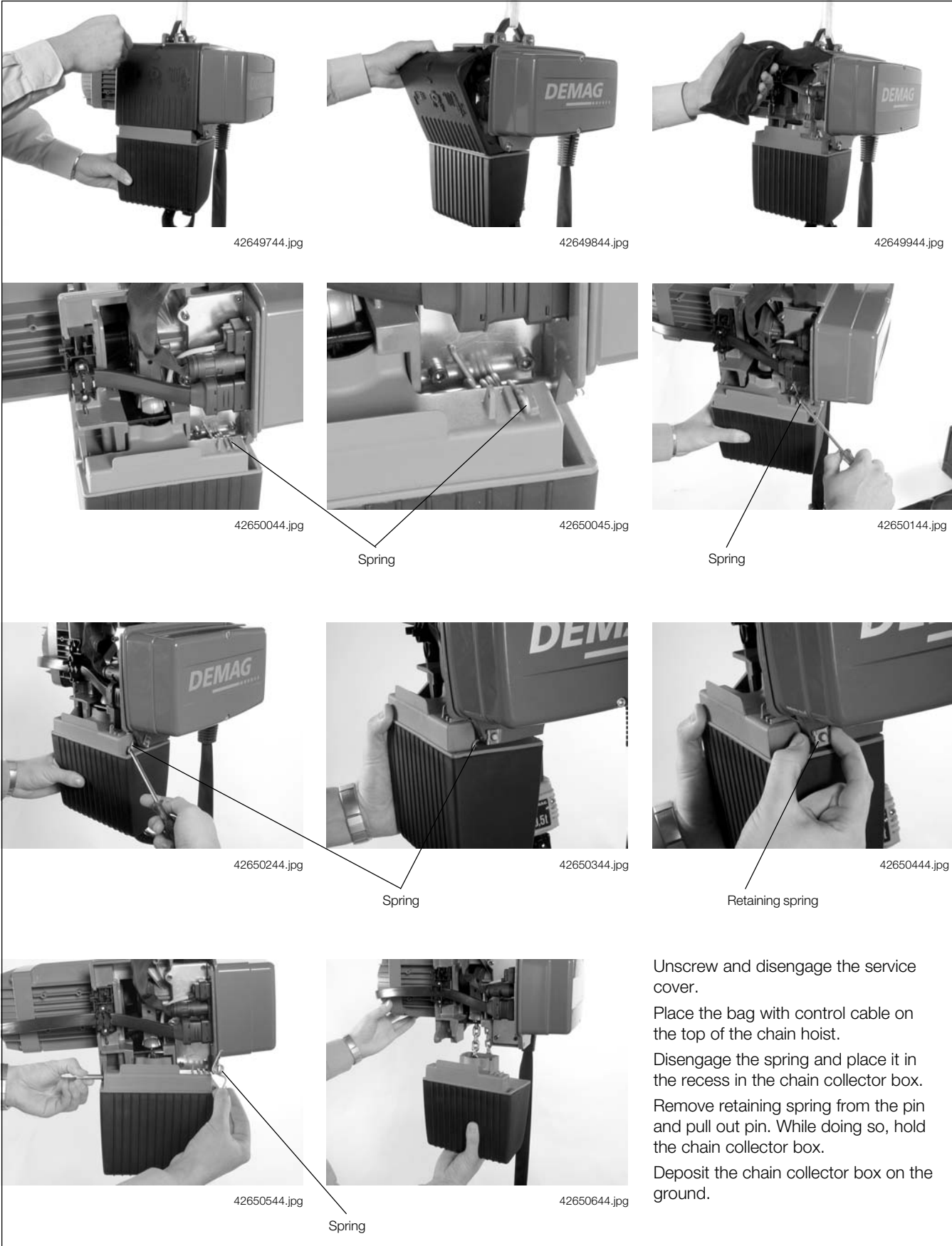

Unscrew and disengage the service cover.

Place the bag with control cable on the top of the chain hoist.

Disengage the spring and place it in the recess in the chain collector box.

Remove retaining spring from the pin and pull out pin. While doing so, hold the chain collector box.

Deposit the chain collector box on the ground.

7.4 Hoist chain



42650744.JPG

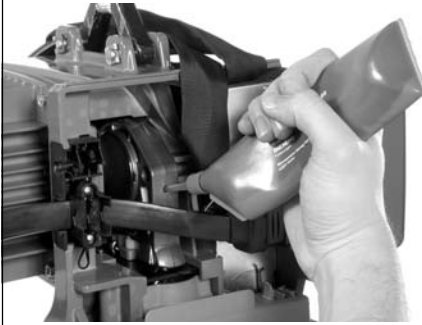

42650844.JPG

The original Demag chain is a tested round section steel chain which is subject to the directives for round section steel chains in hoisting operation of the Main Association of Industrial Employers' Mutual Insurance Societies, Central Department for Accident Prevention and to the test criteria for round section steel chains in hoisting operation and to the inspection regulations.

Lubricating the chain when putting the hoist into operation and during subsequent operation



Before fitting, before lifting a test load and commissioning and during normal operation, the contact surfaces of the chain must be lubricated with a gear grease, part no. 665 009 44, along the entire length of the chain, which must be free of load.

The contact surfaces of chains must be relubricated –after being cleaned –at intervals depending on service and load conditions.

Cut off the tip of the grease tube and insert the grease tube at the lubrication point. To ensure complete and even lubrication of the chain, move the chain into its end positions while you fill the grease into the chain guide by pressing on the tube.

A dry film lubricant should be used in environments where abrasives occur (emery, sand, etc.).

Special chain HS7 on request.

Checking wear or deformation of the original Demag chain



In addition to selecting the correct hoist unit, owners of electric chain hoists are obliged by EN 810 regulations to constantly check the round section steel chain in order to ensure optimum operating safety and, therefore, to avoid serious accidents.

Where normal duty conditions prevail, the chain should be checked once a year (see inspection and maintenance schedule).

If routine maintenance reveals that the intervals are too long or too short, they should be adapted to the specific operating conditions.

A partial load must be suspended from the load hook when measuring the chain for wear or deformation. This measurement can be taken in two different ways.

1. Measurement with a calliper gauge
2. Measurement with a chain gauge

Measuring with a calliper gauge

Measurements on 11 chain links may be taken in steps of 2 x 3 and 1 x 5 chain links (see table 3).

The sum total of the 3 readings taken, i.e. $a_1 + a_2 + a_3$ must not exceed limit a in table 3. Otherwise the chain must be replaced.

Demag is stamped on every 12th link of original Demag chains.

Do you find that, on fitting a new chain, it does not run smoothly over the sprocket?

Please contact our after-sales service centre.

When chains are used that are not approved by Demag, the conditions of the EC conformity declaration and the type test are no longer fulfilled and thus liability for defects is no longer guaranteed.

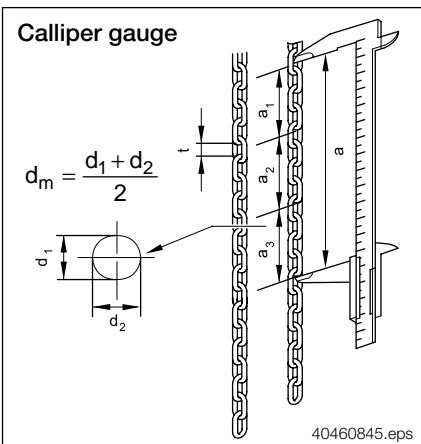

40460845.eps

Table 3

Demag chain hoist	DC-Pro 1	DC-Pro 2	DC-Pro 5	DC-Pro 10	DC-Pro 20
Chain designation d x t	4.2 x 12.2		5.3 x 15.2	7.4 x 21.2	
Limit dimensions according to DIN 685 part 5					
Overall length of 11 links outside, maximum dimension a = a 1 + a 2 + a 3	5.7 in (144.7 mm)		7.1 in (180.3 mm)	9.96 in (253 mm)	
Inside length of 1 link, maximum dimension t	0.5 in (12.8 mm)		0.63 in (15.9 mm)	0.88 in (22.4 mm)	
Measuring the chain link diameter, minimum dimension d m = 0.9 x d	0.15 in (3.8 mm)		0.19 in (4.8 mm)	0.26 in (6.7 mm)	

See sections 7.2 and 7.3 for replacing the chain when required.



When a new chain is ordered, a chain set is always supplied.

(consisting of chain, sprocket, chain guide with plate, chain entry plate, cap and limit stop with buffer)

Chain gauge

Part no. 836 025 44

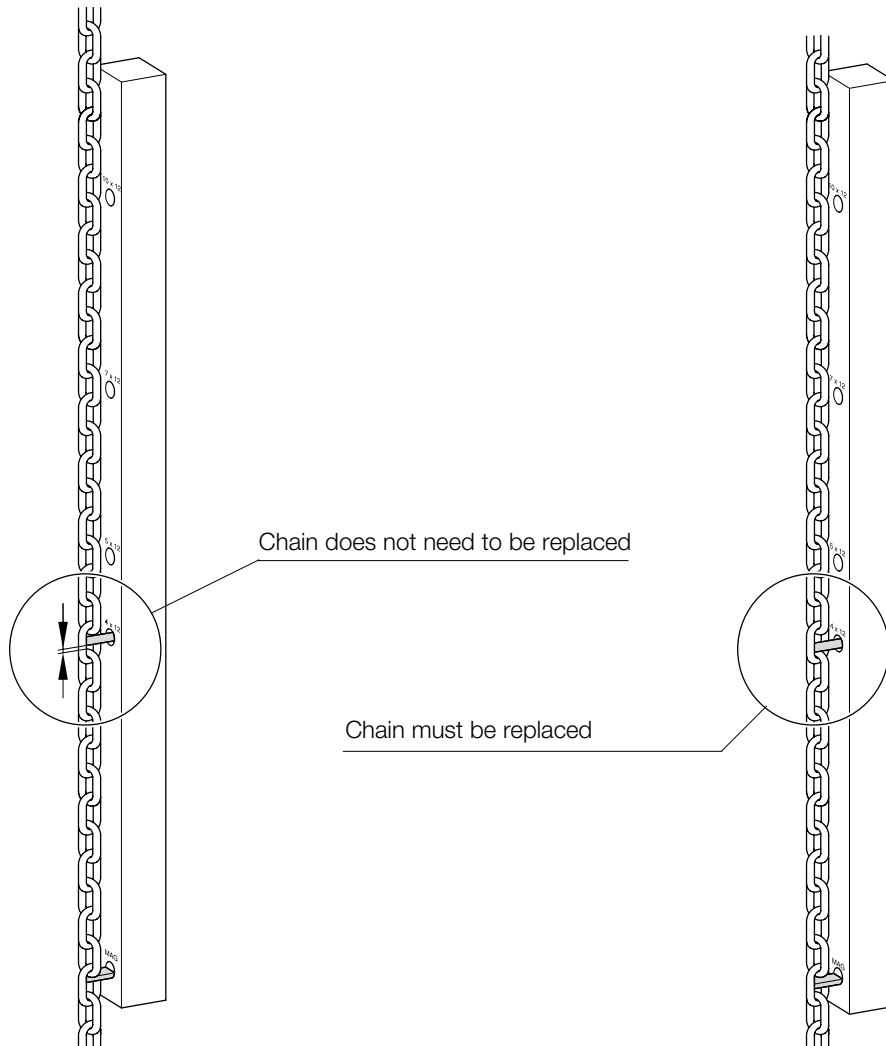

7.5 Load hook, suspension bracket, trolley crossbar

If a check or inspection reveals that these components are worn beyond the dimensions specified or if cracks can be seen in these parts, they must be replaced at once.

Replacing the hook, see section 7.1.

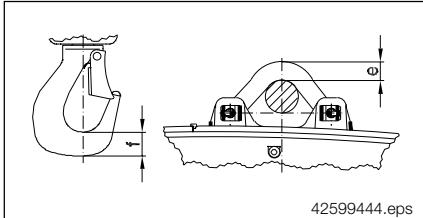

Load hook and suspension bracket

Range	DC-Pro 1/DC-Pro 2 DCM-Pro 1-5		DC-Pro 5		DC-Pro 10		DC-Pro 20	
Load hook in (mm) min. dimension f	0.64 (16.2)		0.76 (19.35)		0.93 (23.6)		1.22 (31.0)	
Suspension bracket	short	long	short	long	short	long	short	long
Suspension bracket min. dimension e in (mm)	0.60 (15.3)	0.57 (14.4)	0.60 (15.3)	0.57 (14.4)	0.99 (25.2)	0.96 (24.3)	0.99 (25.2)	0.96 (24.3)

7.6 Brake

Checking brake wear

1. Disconnect the chain hoist from the power supply (mains connection switch),
2. Open electrical equipment cover (section 7.8),
3. Loosen brake connector,
4. Dismantle brake (three M5 screws, tightening torque 4.06 lb-ft (5.5 Nm)),
5. Determine brake wear with calliper gauge, proceed as follows:
 - Determine distance from brake rear side to brake disk with depth gauge or calliper gauge in non-actuated condition;
 - Measure distance from brake rear side to brake disk with depth gauge or calliper gauge in actuated condition; when this distance is measured, the brake disk must be pressed against the springs. A G clamp may be used to press the brake together;
 - use both measured values to calculate the difference;
 - if the difference does not exceed 0,45 mm, the chain hoist may continue to be operated with the existing brake; if the difference is greater than 0,45 mm, the brake must be replaced;

During assembly, make sure that the area of the V ring on the brake base is slightly greased and the continuous sealing lip is in full contact on the brake rear side.

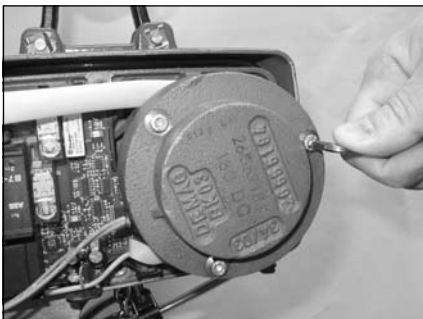

42650944.JPG



42651044.JPG



42651144.JPG

7.7 Checking and adjusting the slip clutch

Under normal operating conditions, the slip clutch does not need to be adjusted. The slip clutch is initially set in the factory. Adjustment of the slip clutch may only be carried out by authorized specialists. An increase of the tripping torque which exceeds the factory setting is not permitted.

We recommend the slip clutch be checked with the friction force checking device, part no. 836 708 44 as part of the annual inspection.



The setting of the slip clutch must be checked once per year for load capacities greater than 2200 lbs (1000 kg).

For further information see Adjusting the slip clutch, document 206 974 44.

Check the slipping clutch function as follows:

- In order to remove the limit stop, the chain collector box must be disconnected, see section 7.3. Remove the limit stop from the section of chain which is not under load, see section 7.1, and fit it above the hook with fittings. Run the limit stop against the guide plate at creep speed. The limit switches must not be actuated while this is being done. If the slip clutch is functioning correctly, the following will be observed:
 - the hoist motor fan is still turning while there is no lifting motion;
 - The 7-segment display shows the SLIP LIFTING V1 warning, see section 7.10.

When the slip clutch function has been checked, the limit stop must be fitted again to the section of chain which is not under load.

7.8 Replacing the cables

Replacing the control cable

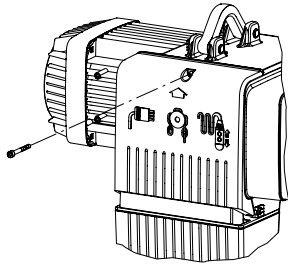

42596644.eps

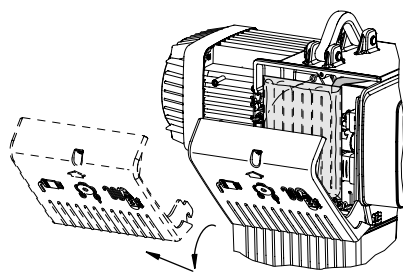

42596744.eps

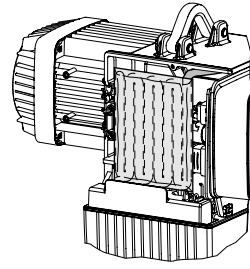

42596844.eps

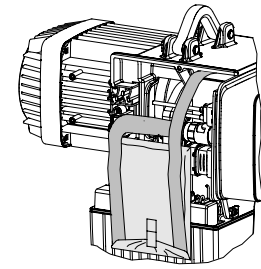

42596944.eps

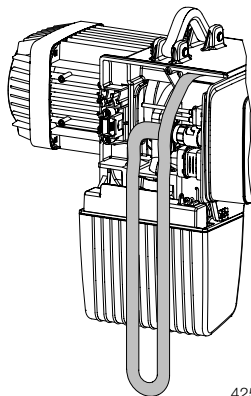

42597344.eps

Disconnect the chain hoist from the power supply (mains connection switch).
 Open and disengage the service cover.
 Remove and open the bag with the control cable.
 Take the control cable out of the bag.
 Loosen bayonet lock by turning and remove control cable plug connection.
 Unscrew electrical equipment cover.
 Loosen the screw on the control cable lock and remove the lock.
 Remove the control cable.
 The new control cable is installed in reverse order. It must be ensured that

- the groove of the connector holder matches the swivel lock in the enclosure and
- that the two pins on the enclosure match the bayonet lock.

See also assembly of the control pendant, section 4.2.
 See also control pendant height adjustment, section 4.4.

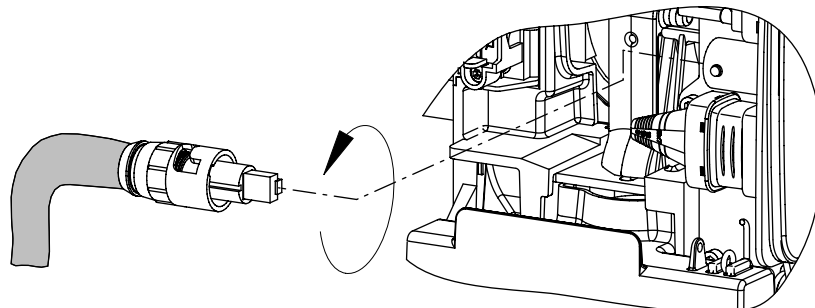
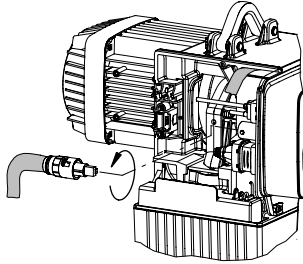

42597445.eps

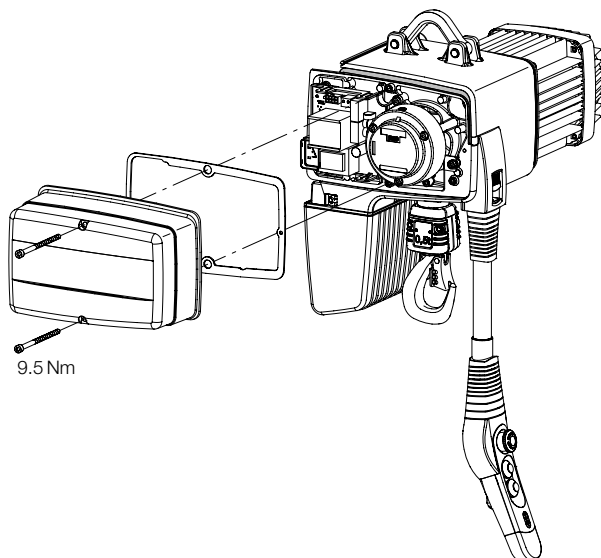

9.5 Nm

42597544.eps

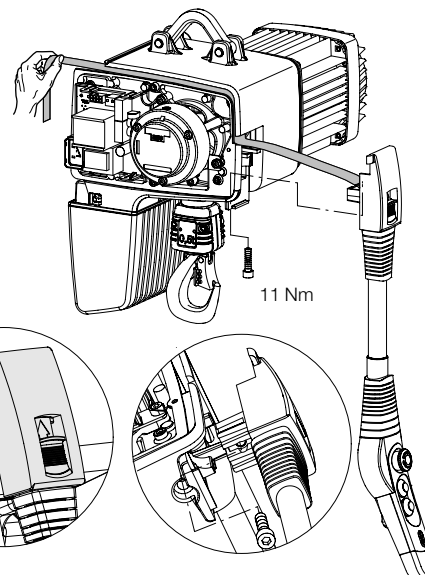

11 Nm

42597644.eps

Replacing the helical cable



Work on the electrical equipment may only be carried out by a qualified electrician or by trained personnel.

The Demag chain hoist is supplied with the helical cable connected. If a helical cable has to be replaced, the leads must be connected as shown in the circuit diagram.

Disconnect the chain hoist from the power supply (mains connection switch).
 Open and disengage the service cover.
 Loosen bayonet lock by turning and remove helical cable plug connection.
 Unscrew electrical equipment cover.
 Loosen the screw on the helical cable lock and remove the lock.
 Remove the helical cable.
 Fit the new helical cable in reverse order. It must be ensured that

- the groove of the connector holder matches the swivel lock in the enclosure and
- that the two pins on the enclosure match the bayonet lock.

See also Replacing the control cable.

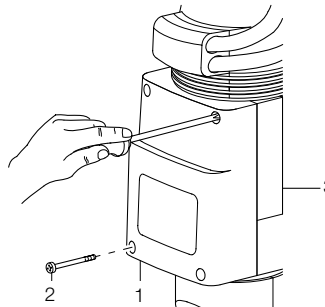

41104644.eps

Undo the four screws (2) to remove cover (1). Tighten diagonal pairs of screws when re-fitting the cover.

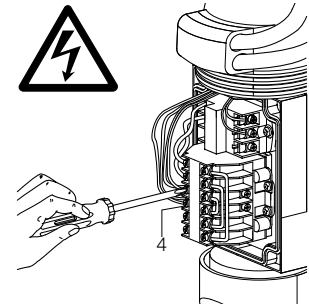

41104744.eps

Disconnect electrical leads (4).



Only connect according to the circuit diagram, see section 7.9.

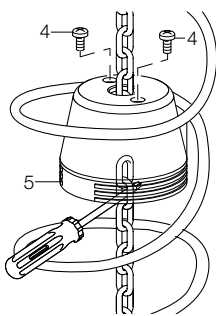

41104844.eps

Undo cap screws (4), slide cap (5) upwards and secure against dropping (e.g. with a screwdriver).

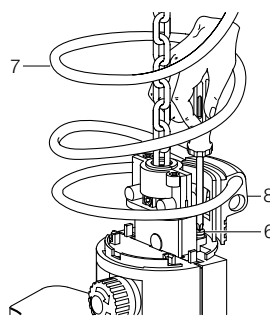

41104944.eps

Undo flanged cable entry sleeve (6), remove helical cable (7). When fitting the new cable, seal by tightening the flanged cable entry sleeve with rubber seal.



First fit helical cable inlet (8) to centering rib of housing and ensure helical cable is correctly arranged.

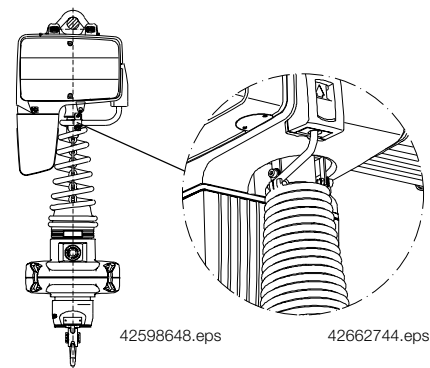

42598648.eps

42662744.eps

Disconnect helical cable, screws and pipe clamps from the adapter ring.

7.9 Circuit diagrams and control card

DC-Pro 1, DC-Pro 2, DC-Pro 5, DC-Pro 10, DC-Pro 20

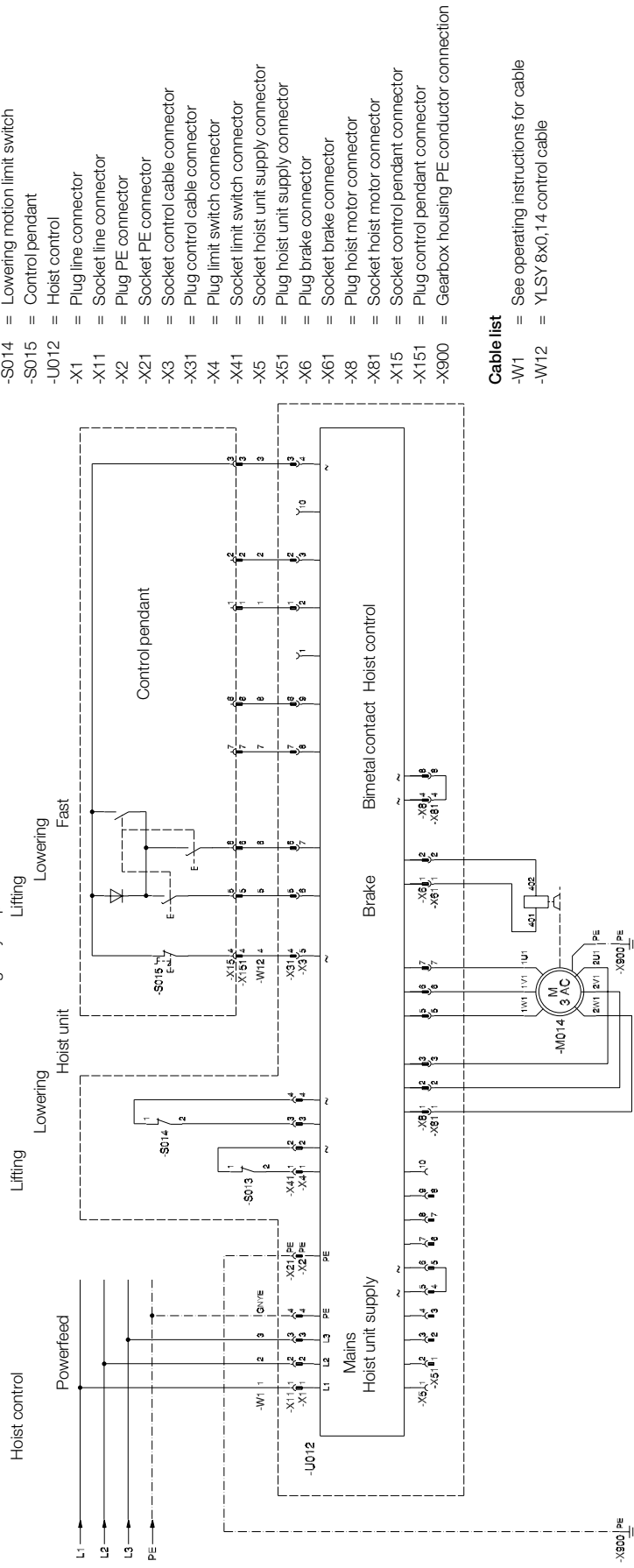

Device list

- M014 = Hoist motor
- S013 = Lifting motion limit switch
- S014 = Lowering motion limit switch
- S015 = Control pendant
- U012 = Hoist control
- X1 = Plug line connector
- X11 = Socket line connector
- X2 = Plug PE connector
- X21 = Socket PE connector
- X3 = Socket control cable connector
- X31 = Plug control cable connector
- X4 = Plug limit switch connector
- X41 = Socket limit switch connector
- X5 = Socket hoist unit supply connector
- X51 = Plug hoist unit supply connector
- X6 = Plug brake connector
- X61 = Socket brake connector
- X8 = Plug hoist motor connector
- X81 = Socket hoist motor connector
- X15 = Socket control pendant connector
- X151 = Plug control pendant connector
- X900 = Gearbox housing PE conductor connection

Cable list

- W1 = See operating instructions for cable
- W12 = YLSY 8x0,14 control cable

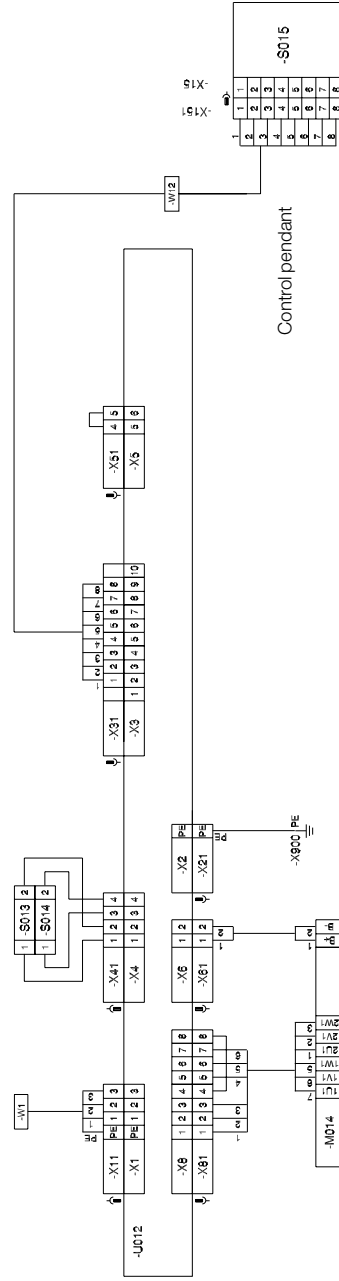

See section 2.4 for required power supply cable cross sections and mains fuse links.

DCM 1-5

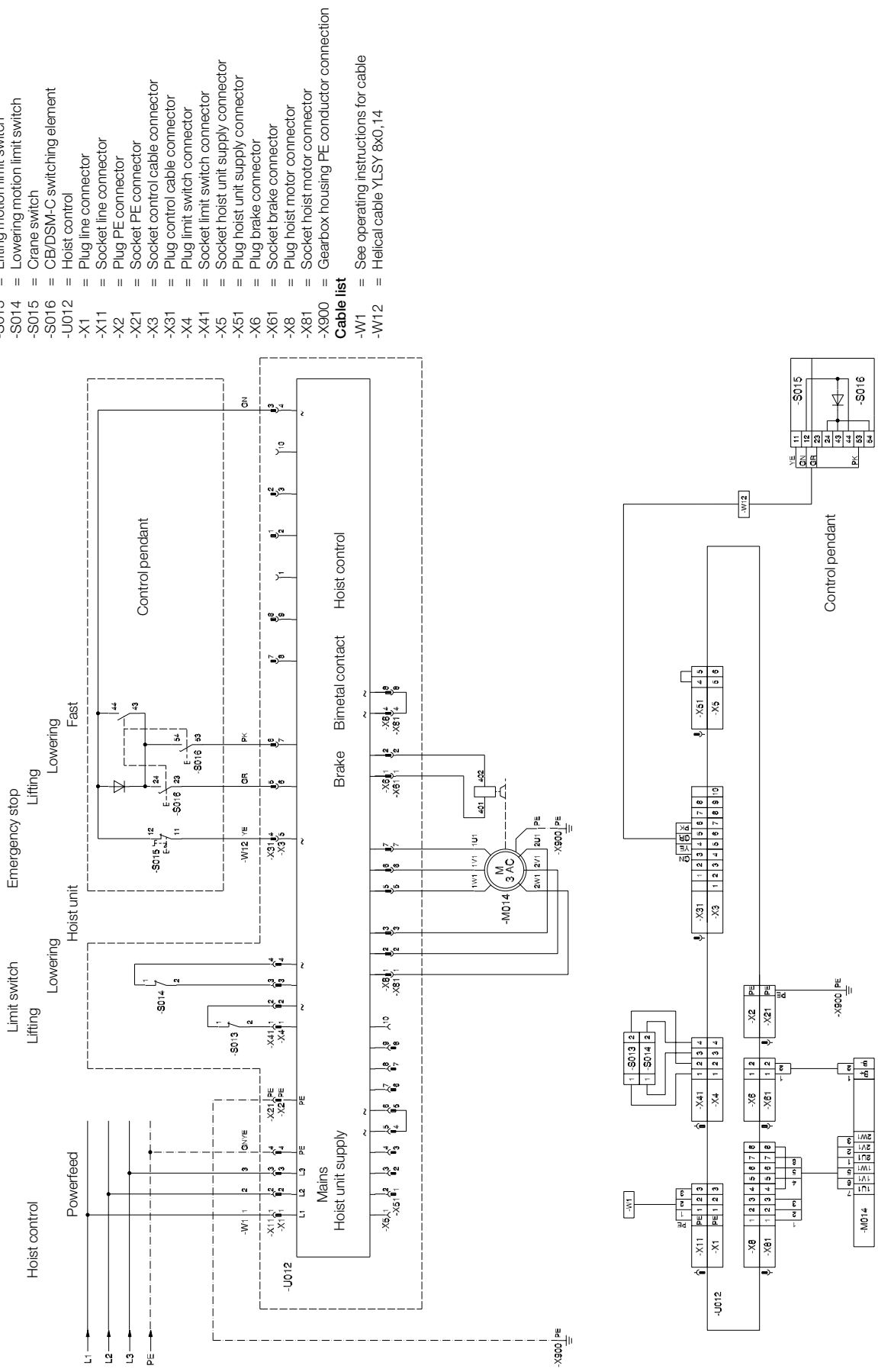

- Device list**
- M014 = Hoist motor
 - S013 = Lifting motion limit switch
 - S014 = Lowering motion limit switch
 - S015 = Crane switch
 - S016 = CB/DSM-C switching element
 - U012 = Hoist control
 - X1 = Hoist line connector
 - X11 = Socket line connector
 - X2 = Plug PE connector
 - X21 = Socket PE connector
 - X3 = Socket control cable connector
 - X31 = Plug control cable connector
 - X4 = Plug limit switch connector
 - X41 = Socket limit switch connector
 - X5 = Socket hoist unit supply connector
 - X51 = Plug hoist unit supply connector
 - X6 = Plug brake connector
 - X61 = Socket brake connector
 - X8 = Plug hoist motor connector
 - X81 = Socket hoist motor connector
 - X900 = Gearbox housing PE conductor connection
- Cable list**
- W1 = See operating instructions for cable
 - W12 = Helical cable YLSY 8x0,14

See section 2.4 for required power supply cable cross sections and mains fuse links.

Control card variants

	Voltage range [V]	Frequency [Hz]	Part no.
DC-Pro 1 / 2 / 5	460 - 480	60	720 120 45
	440 - 455		
	220 - 240		720 220 45
	575		720 320 45
DC-Pro 10 / 20	460 - 480	60	720 160 45
	440 - 455		-
	220 - 240		-
	575		720 360 45

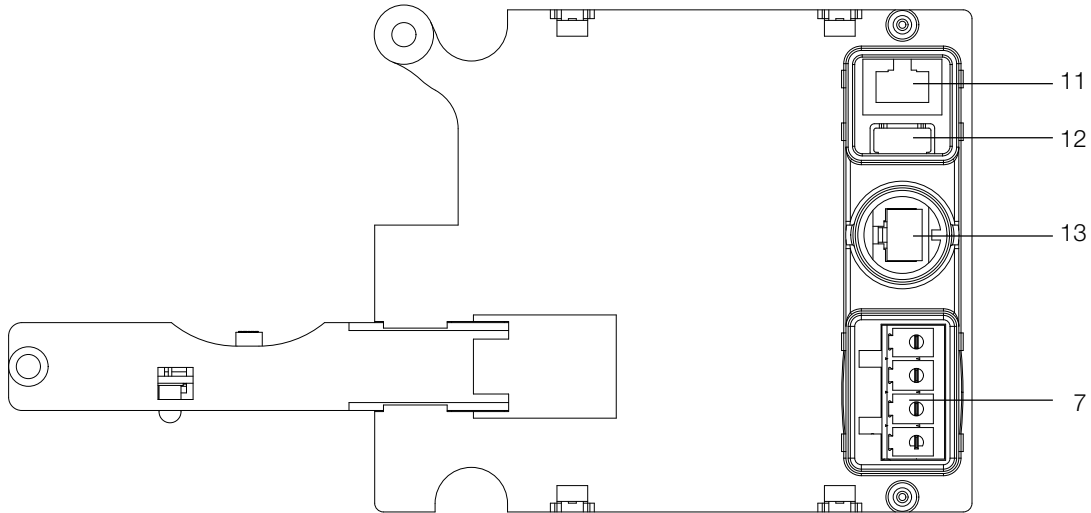
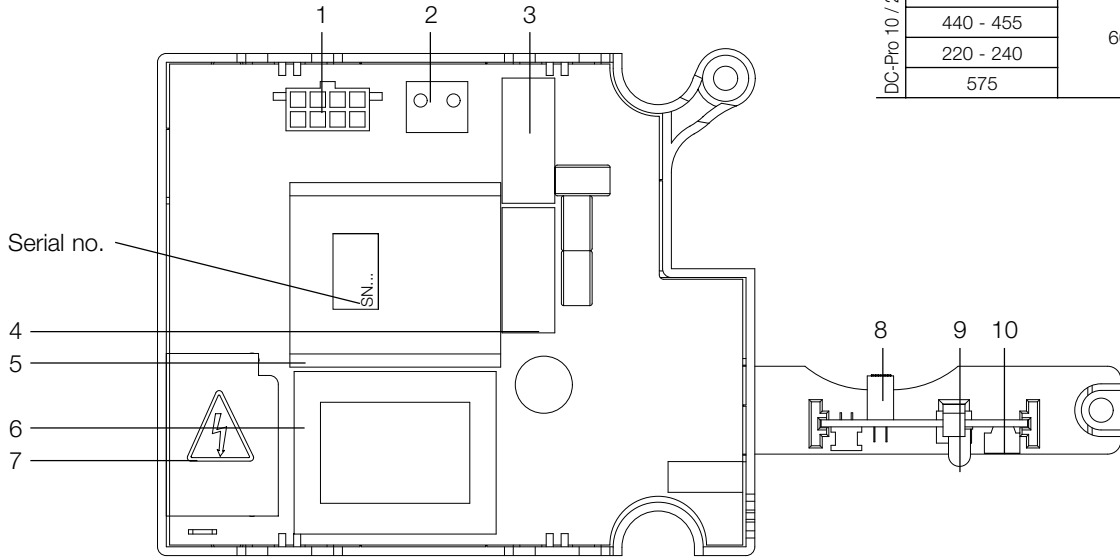



42648044.eps

Item	Designation	Function
1	Plug-in connection	Motor connection
2	Plug-in connection	Brake connection
3	Relay	Fast / Slow
4	Relay	Lifting / Lowering
5	Contactor	On / Off
6	Transformer	
7	Plug-in connection	Line connection
8	Fork-type light barrier	Pulse encoder
9	IR transmitter diode	IR interface
10	7-segment LED	Multi-function display e.g.: operating hour counter, status display, error code display
11	Dummy plug	Trolley connection (optional): DC-Pro 10 + 20 items 11 + 12 swapped
12	Plug-in connection	Lifting limit switch connection: DC-Pro 10 + 20 items 11 + 12 swapped
13	Plug-in connection	Control cable connection

7.10 Warning messages and error statuses

Warning messages

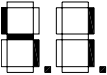
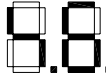
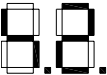
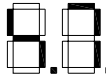
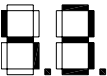
Warning messages start with the lightning symbol.

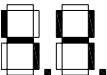
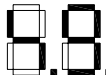
- | | | | | | |
|----|---|----------------------------------|----|---|---|
| 1. |  | SLIP LIFTING start-up | 6. |  | Hardware monitoring fault
no speed information |
| 2. |  | SLIP LIFTING V1 | 7. |  | SLIP LOWERING start-up |
| 3. |  | SLIP LIFTING V2 | 8. |  | SLIP LOWERING V1 |
| 4. |  | Error in internal data
memory | 9. |  | SLIP LOWERING V2 |



Symbols are shown one after the other.

42599646.eps





Error statuses

E1 to E7, see instructions for finding faults

7.11 Instructions for finding faults

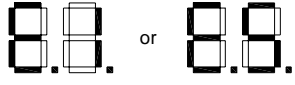
Failed safety functions

In the cases 1 to 6, a safety function has failed. Operation may only be continued after repair.

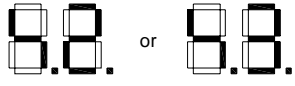
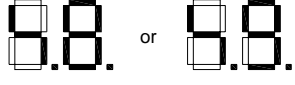
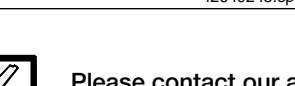
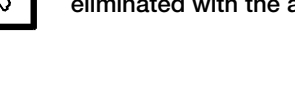
No.	Error	Display	Possible cause	Remarks
1	Chain hoist is blocked	 or 	Hardware error of the control system	Check error message by actuating and unlocking the emergency stop. Then actuate Lowering. If necessary, remove suspended load.
2				
3			Direction cannot be switched	
4	Load > 160% is being lifted		Slipping clutch	Danger owing to exceeding the maximum permitted load on supporting parts. Slipping force must be set to permissible values by an experienced technician.
5	Switching off in the upper end position	 or 	Limit switch contact is not actuated	In the case of error-free functioning of the limit switches (-.) is displayed. In the event of an error, the slipping clutch functions as an emergency limit stop device: Connection and functioning of the limit switch contact must be inspected by an experienced technician.
6	Switching off in the lower end position	 or 		







42649245.eps



Please contact our after-sales service if the cause of a fault cannot be eliminated with the above measures.

Errors

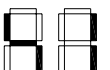
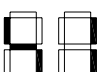
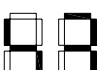
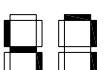
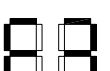
Functioning of the chain hoist is only possible when it is correctly connected to the power supply. In the event of a failure, therefore first check cables, strain relief and power supply connections. Malfunctions may also be caused by incorrect transmission of commands from the control pendant. Therefore, check the control pendant and the control cable for damage and the plug-in connector on the pendant and in the service enclosure for correct fit.

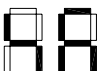
No.	Error	Display	Possible cause	Remarks
7	No lifting, no lowering.	Display dark.	No power supply.	Check mains connection and fuse link; check connection cable for interruption; check mains connector in the service enclosure.
8	No lifting, no lowering.		Emergency stop actuated. Emergency stop cable is interrupted.	Unlock emergency stop button by turning. Check dummy plug for trolley connection. Check connections of the control cable on the pendant and in the service enclosure.
9	Upper or lower end position has been reached. No lifting, no lowering.		Incorrect direction of revolution of motor.	Two phases of the mains connection cable must be changed. First disconnect unit from the power supply.
10	No lifting, no lowering.		When power is switched on or when the emergency stop is unlocked, a button is already actuated.	Release button and actuate it again.
11	No lifting, no lowering.		Control cable is interrupted.	Check connections of the control cable on the pendant and in the service enclosure. Check control cable for continuity.
12	No lifting.		Mains phase missing or motor blocked.	Check mains connection and fuse link; check connection cable for interruption; check mains connector in the service enclosure.
13	No lifting with load.		Chain hoist overloaded or undervoltage.	Reduce load to the permissible load capacity. Ensure appropriate mains voltage.
14	Fast lifting with load is switched off.		Chain hoist overloaded.	Reduce load to the permissible load capacity.
15	No lowering.		Mains phase missing or motor blocked.	Check mains connection and fuse link; check connection cable for interruption; check mains connector in the service enclosure.
16	Lowering with load is switched off.		Lowering speed too high.	Reduce load to the permissible load capacity. Check mains connection and fuse link; check connection cable for interruption; check mains connector in the service enclosure.
17	Lowering is switched off, lower end position is not reached.	 or 	Chain blocked.	Check chain running in, replace chain, if required.
18	No load motion while lifting		Drive blocked	Repeat hoist motion; if the load does not move, have brake and control system checked by an experienced technician.

42649345.eps

Symbols are shown one after the other.



Please contact our after-sales service if the cause of a fault cannot be eliminated with the above measures.

8 Component parts

DC-Pro 1 and DC-Pro 2

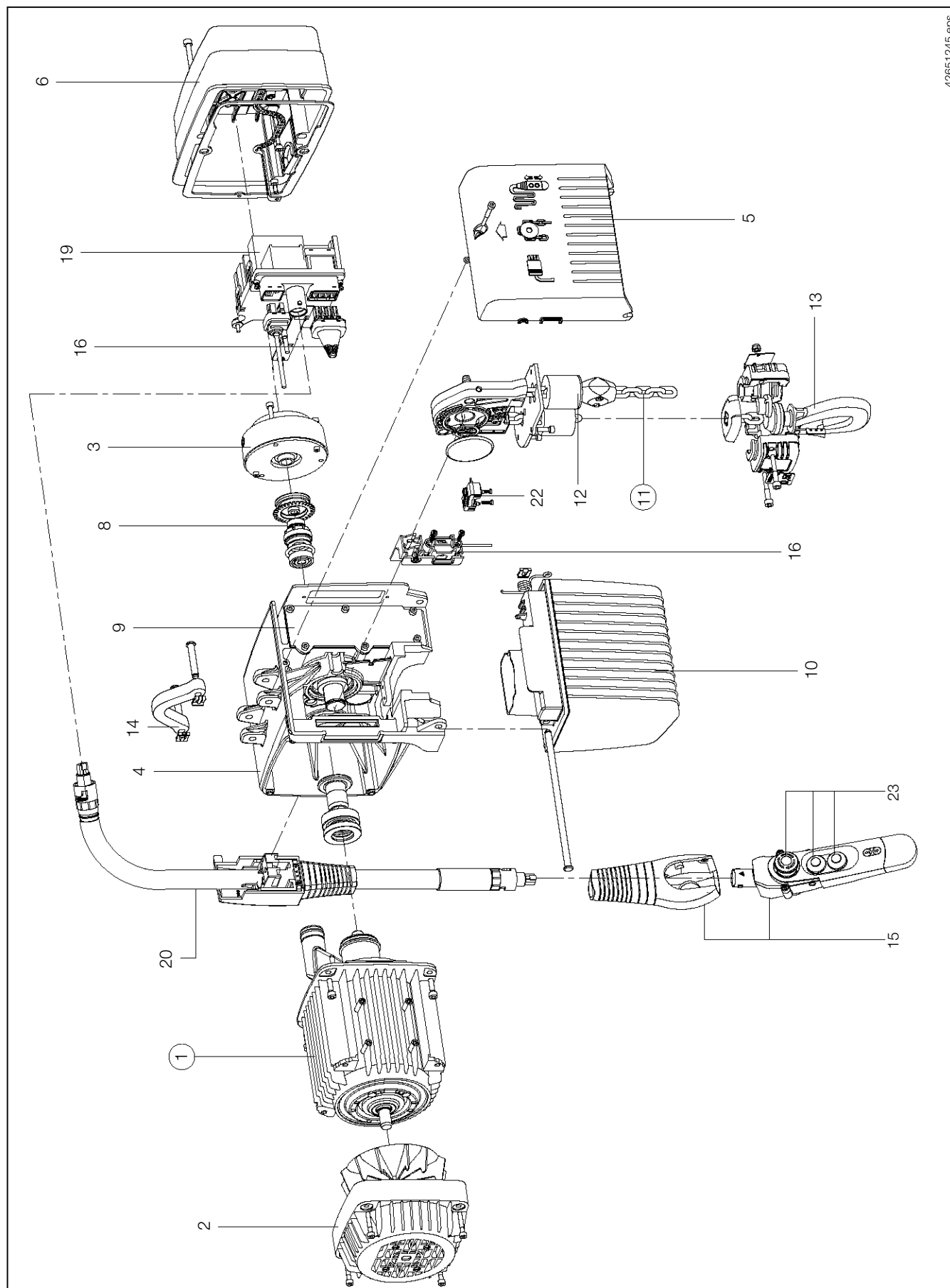

42651245.eps

DC-Pro 1 and DC-Pro 2

Item no.	Part no.	Quantity	Designation	Material	Standard
1	71784133	1	Motor set 240V50Hz	c/w item 2, 220 V - 240 V, 50 Hz, 7 lb-ft (9.5 Nm)	
1	71784233	1	Motor set 415V50Hz	c/w item 2, 380 V - 415 V, 50 Hz, 7 lb-ft (9.5 Nm)	
1	71784333	1	Motor set 480V60Hz	c/w item 2, 460 V - 480 V, 60 Hz, 7 lb-ft (9.5 Nm)	
1	71784433	1	Motor set 575V60Hz	c/w item 2, 575 V, 60 Hz, 7 lb-ft (9.5 Nm)	
1	71784533	1	Motor set 460V60Hz	c/w item 2, 440 V - 455 V, 60 Hz, 7 lb-ft (9.5 Nm)	
1	71784633	1	Motor set 240V60Hz	c/w item 2, 220 V - 240 V, 60 Hz, 7 lb-ft (9.5 Nm)	
1	71784733	1	Motor set 380V60Hz	c/w item 2, 380 V, 60 Hz, 7 lb-ft (9.5 Nm)	
2	71785033	1	Fan set DC 2	3 lb-ft (4 Nm)	
3	71887133	1	Brake set 180V	380 V - 415 V, 50 Hz, 4.05 lb-ft (5.5 Nm)	
3	71887233	1	Brake set 208V	440 V - 480 V, 60 Hz, 4.05 lb-ft (5.5 Nm)	
3	71887333	1	Brake set 104V	220 V - 240 V, 50/60 Hz, 4.05 lb-ft (5.5 Nm)	
3	71887433	1	Brake set 258V	575 V, 60 Hz, 4.05 lb-ft (5.5 Nm)	
4	71790533	1	Gearbox set V1		
4	71790633	1	Gearbox set V2		
5	71792033	1	Service hood set DC 2	4.05 lb-ft (5.5 Nm)	
6	71792133	1	Electrical equipm.hood set DC 2	7 lb-ft (9.5 Nm)	
8	71894733	1	Adjustment nut/pulse wheel		
9	71791933	1	Gear oil/seal Pro 2		
10	71798633	1	Chain collector box set 5m		
10	71798733	1	Chain collector box set 8m		
11	71795033	1	Chain set DC1/DC2 5m	c/w item 12, 2.95 lb-ft (4.0 Nm)	
11	71795133	1	Chain set DC1/DC2 8m	c/w item 12, 2.95 lb-ft (4.0 Nm)	
12	71795333	1	Buffer set	V1, V2	
13	71798033	1	Hook fittings set DC1/2	5.01 lb-ft (6.8 Nm)	
14	71897433	1	Suspension set		
15	77330033	1	Controller DSC		
16	71885633	1	Slide-in unit/plug		
19	71882033	1	Control set 400V	380 V - 415 V, 50 Hz, 2.21 lb-ft (3 Nm)	
19	71882133	1	Control set 460V	440 V - 480 V, 60 Hz, 2.21 lb-ft (3 Nm)	
19	71882233	1	Control set 230V	220 V - 240 V, 50/60 Hz, 2.21 lb-ft (3 Nm)	
19	71882333	1	Control set 575V	575 V, 60 Hz, 2.21 lb-ft (3 Nm)	
20	71881033	1	Control cable set 5m	8.11 lb-ft (11 Nm)	
20	71880933	1	Control cable set 8m	8.11 lb-ft (11 Nm)	
22	71888033	1	Limit switch set	1.11 lb-ft (1.5 Nm)	
23	71880433	1	Emergency-stop set/rubber cap DSC	Controller	

21474002.tbl

DC-Pro 5

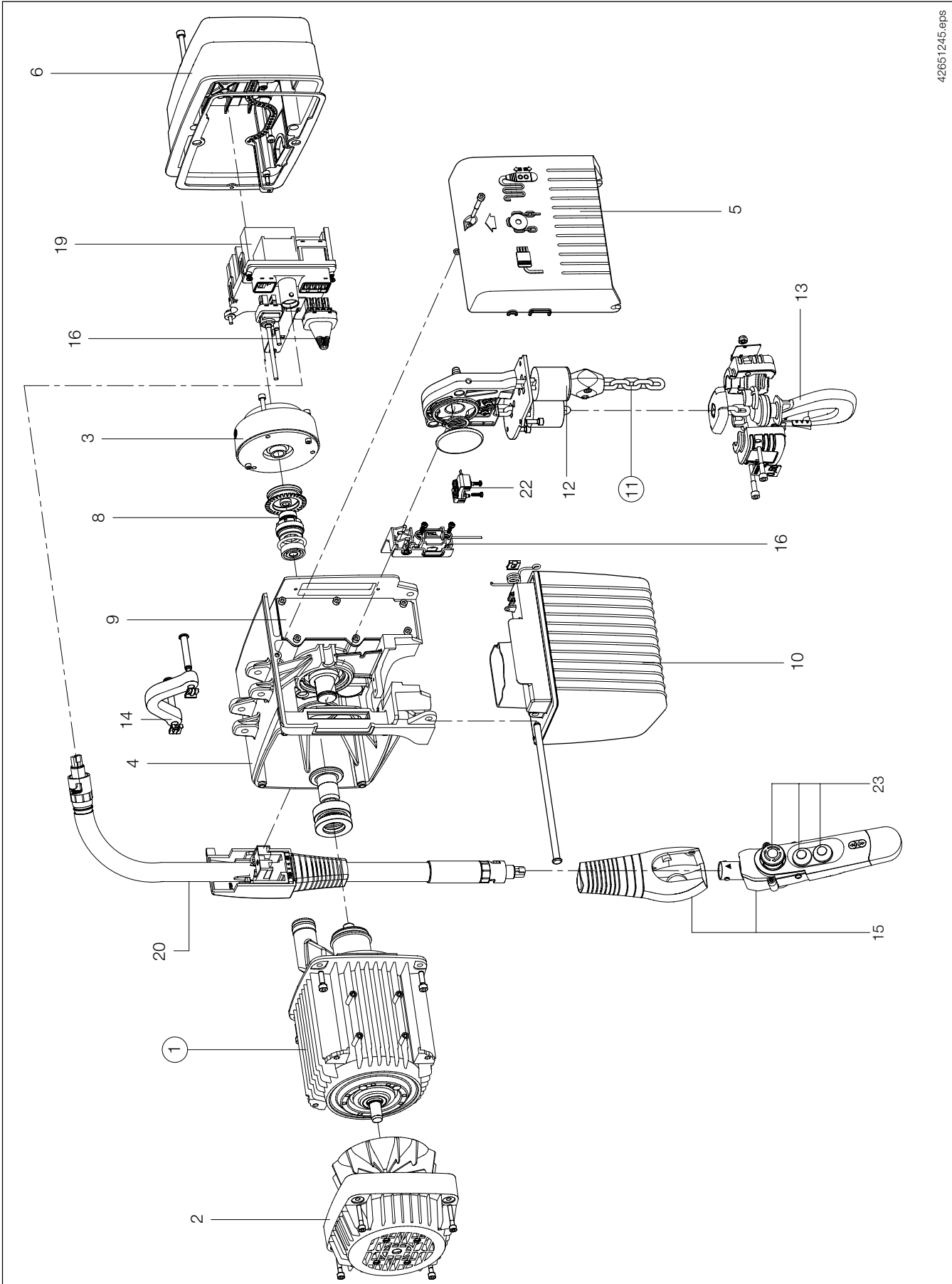

42651245.eps

DC-Pro 5

Item no.	Part no.	Quantity	Designation	Material	Standard
1	71884133	1	Motor set 240V50Hz	c/w item 2, 220 V - 240 V, 50 Hz, 7 lb-ft (9.5 Nm)	
1	71884233	1	Motor Set 415V50Hz	c/w item 2, 380 V - 415 V, 50 Hz, 7 lb-ft (9.5 Nm)	
1	71884333	1	Motor set 480V60Hz	c/w item 2, 460 V - 480 V, 60 Hz, 7 lb-ft (9.5 Nm)	
1	71884433	1	Motor set 575V60Hz	c/w item 2, 575 V, 60 Hz, 7 lb-ft (9.5 Nm)	
1	71884533	1	Motor set 460V60Hz	c/w item 2, 440 V - 455 V, 60 Hz, 7 lb-ft (9.5 Nm)	
1	71884633	1	Motor set 240V60Hz	c/w item 2, 220 V - 240 V, 60 Hz, 7 lb-ft (9.5 Nm)	
1	71884733	1	Motor set 380V60Hz	c/w item 2, 380 V, 60 Hz, 7 lb-ft (9.5 Nm)	
2	71885033	1	Fan set	3 lb-ft (4 Nm)	
3	71887133	1	Brake set 180V	380 V - 415 V, 50 Hz, 4.05 lb-ft (5.5 Nm)	
3	71887233	1	Brake set 208V	440 V - 480 V, 60 Hz, 4.05 lb-ft (5.5 Nm)	
3	71887333	1	Brake set 104V	220 V - 240 V, 50/60 Hz, 4.05 lb-ft (5.5 Nm)	
3	71887433	1	Brake set 258V	575 V, 60 Hz, 4.05 lb-ft (5.5 Nm)	
4	71890533	1	Gearbox set V1		
4	71890633	1	Gearbox set V2		
5	71892033	1	Service hood set DC 5	4.05 lb-ft (5.5 Nm)	
6	71892133	1	Electrical equipm.hood set DC 5	7 lb-ft (9.5 Nm)	
8	71894733	1	Adjustment nut/pulse wheel		
9	71891933	1	Gear oil/seal Pro 5		
10	71898633	1	Chain collector box set 5m		
10	71898733	1	Chain collector box set 8m		
11	71895033	1	Chain set DC 5 5m	c/w item 12, 3.17 lb-ft (4.3 Nm)	
11	71895133	1	Chain set DC 5 8m	c/w item 12, 3.17 lb-ft (4.3 Nm)	
12	71895333	1	Buffer set	V1, V2	
13	71898033	1	Hook fittings set DC5	8.47 lb-ft (11.5 Nm)	
14	71897433	1	Suspension set		
15	77330033	1	Controller DSC		
16	71885633	1	Slide-in unit/plug		
19	71882033	1	Control set 400V	380 V - 415 V, 50 Hz, 2.21 lb-ft (3 Nm)	
19	71882133	1	Control set 460V	440 V - 480 V, 60 Hz, 2.21 lb-ft (3 Nm)	
19	71882233	1	Control set 230V	220 V - 240 V, 50/60 Hz, 2.21 lb-ft (3 Nm)	
19	71882333	1	Control set 575V	575 V, 60 Hz, 2.21 lb-ft (3 Nm)	
20	71881033	1	Control cable set 5m	8.11 lb-ft (11 Nm)	
20	71880933	1	Control cable set 8m	8.11 lb-ft (11 Nm)	
22	71888033	1	Limit switch set	1.11 lb-ft (1.5 Nm)	
23	71880433	1	Emergency-stop set/rubber cap DSC	Controller	

21474003.tbl

DC-Pro 10 and DC-Pro 20, 1/1 reeving, < 2200 lbs (1000 kg)

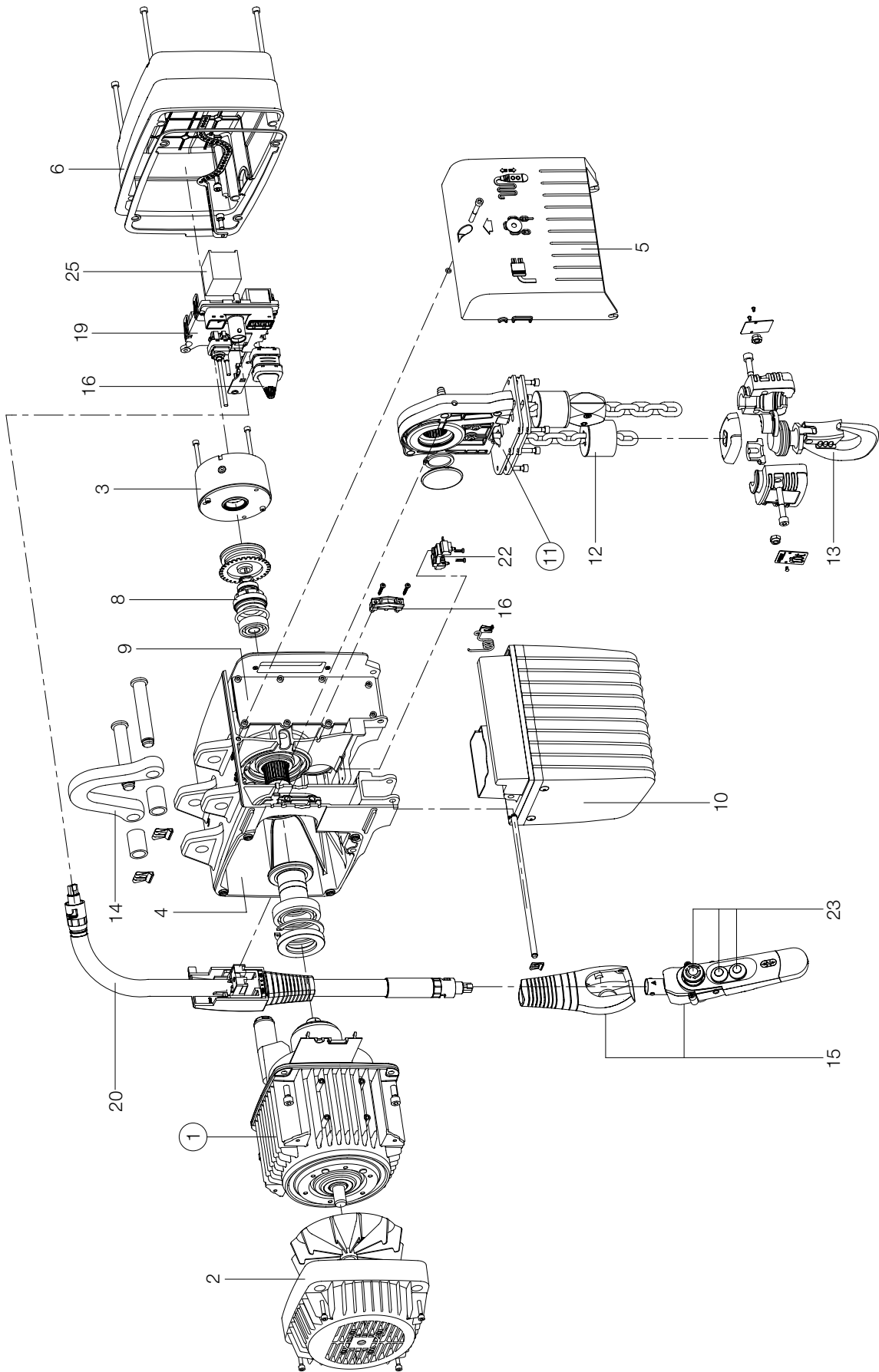

42674344.eps

DC-Pro 10 und DC-Pro 20, 1/1 reeving, < 2200 lbs (1000 kg)

Item no.	Part no.	Quantity	Designation	Material	Standard
1	71584233	1	Motor set 415V50Hz A	c/w item 2, 380 V - 415 V, 50 Hz, 18.44 lb-ft (25 Nm)	
1	71584333	1	Motor set 480V60Hz A	c/w item 2, 460 V - 480 V, 60 Hz, 18.44 lb-ft (25 Nm)	
1	71584433	1	Motor set 575V60Hz A	c/w item 2, 575 V, 60 Hz, 18.44 lb-ft (25 Nm)	
1	71584533	1	Motor set 460V60Hz A	c/w item 2, 440 V - 455 V, 60 Hz, 18.44 lb-ft (25 Nm)	
1	71584733	1	Motor set 380V60Hz A	c/w item 2, 380 V, 60 Hz, 18.44 lb-ft (25 Nm)	
1	71583233	1	Motor set 415V50Hz B	c/w item 2, 380 V - 415 V, 50 Hz, 18.44 lb-ft (25 Nm)	
1	71583333	1	Motor set 480V60Hz B	c/w item 2, 460 V - 480 V, 60 Hz, 18.44 lb-ft (25 Nm)	
1	71583433	1	Motor set 575V60Hz B	c/w item 2, 575 V, 60 Hz, 18.44 lb-ft (25 Nm)	
1	71583533	1	Motor set 460V60Hz B	c/w item 2, 440 V - 455 V, 60 Hz, 18.44 lb-ft (25 Nm)	
1	71583733	1	Motor set 380V60Hz B	c/w item 2, 380 V, 60 Hz, 18.44 lb-ft (25 Nm)	
2	71585033	1	Fan set A	2.95 lb-ft (4 Nm)	
2	71585133	1	Fan set B	2.95 lb-ft (4 Nm)	
3	71587133	1	Brake set DC10/20 180V	380 V - 415 V, 50 Hz, 4.05 lb-ft (5.5 Nm)	
3	71587233	1	Brake set DC10/20 208V	440 V - 480 V, 60 Hz, 4.05 lb-ft (5.5 Nm)	
3	71587433	1	Brake set DC10/20 258V	575 V, 60 Hz, 4.05 lb-ft (5.5 Nm)	
4	71590533	1	Gearbox set DC10 V1		
4	71590633	1	Gearbox set DC10/20 V2		
5	71592033	1	Service hood set DC10/20	5.53 lb-ft (7.5 Nm)	
6	71592133	1	Electrical equipm.hood set DC10/20	7.00 lb-ft (9.5 Nm)	
8	71594733	1	Adjustment nut/pulse wheel		
9	71591933	1	Gear oil/seal/slipping clutch		
10	71598633	1	Chain collector box set 5m		
10	71598733	1	Chain collector box set 8m		
11	71595033	1	Chain set DC 5m 1/1	c/w item 12, 7.00 lb-ft (9.5 Nm)	
11	71595133	1	Chain set DC 8m 1/1	c/w item 12, 7.00 lb-ft (9.5 Nm)	
12	71595333	1	Buffer set	V1, V2	
13	71598033	1	Hook fittings set DC10/20	18.44 lb-ft (25 Nm)	
14	71597433	1	Suspension set		
15	77330033	1	Controller DSC		
16	71885633	1	Slide-in unit/plug		
19	71582033	1	Control set 400V	380 V - 415 V, 50 Hz, 2.21 lb-ft (3 Nm)	
19	71582133	1	Control set 460V	440 V - 480 V, 60 Hz, 2.21 lb-ft (3 Nm)	
19	71582333	1	Control set 575V	575 V, 60 Hz, 2.21 lb-ft (3 Nm)	
20	71881033	1	Control cable set 5m	7.74 lb-ft (10.5 Nm)	
20	71880933	1	Control cable set 8m	7.74 lb-ft (10.5 Nm)	
22	71588033	1	Limit switch set	2.21 lb-ft (3 Nm)	
23	71880433	1	Emergency-stop set/rubber cap DSC	Controller	
25	71582533	1	Contact set		

21474005.tbl

DC-Pro 20, 2/1 reeving, > 2200 lbs (1000 kg)

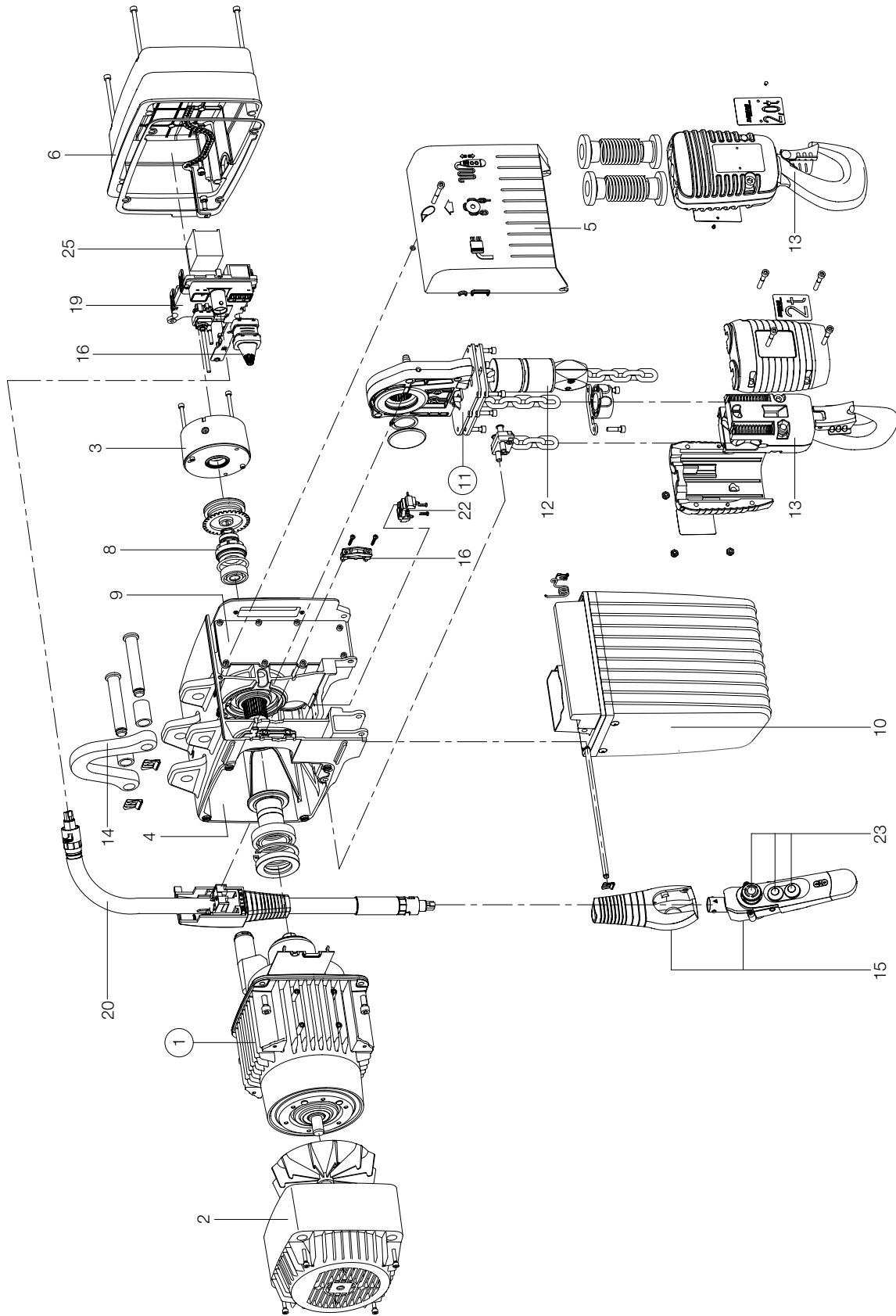

42674444.eps

DC-Pro 20, 2/1 reeving, > 2200 lbs (1000 kg)

Item no.	Part no.	Quantity	Designation	Material	Standard
1	71583233	1	Motor set 415V50Hz B	c/w item 2, 380 V - 415 V, 50 Hz, 18.44 lb-ft (25 Nm)	
1	71583333	1	Motor set 480V60Hz B	c/w item 2, 460 V - 480 V, 60 Hz, 18.44 lb-ft (25 Nm)	
1	71583433	1	Motor set 575V60Hz B	c/w item 2, 575 V, 60 Hz, 18.44 lb-ft (25 Nm)	
1	71583533	1	Motor set 460V60Hz B	c/w item 2, 440 V - 455 V, 60 Hz, 18.44 lb-ft (25 Nm)	
1	71583733	1	Motor set 380V60Hz B	c/w item 2, 380 V, 60 Hz, 18.44 lb-ft (25 Nm)	
2	71585133	1	Fan set B	2.95 lb-ft (4 Nm)	
3	71587133	1	Brake set DC10/20 180V	380 V - 415 V, 50 Hz, 4.05 lb-ft (5.5 Nm)	
3	71587233	1	Brake set DC10/20 208V	440 V - 480 V, 60 Hz, 4.05 lb-ft (5.5 Nm)	
3	71587433	1	Brake set DC10/20 258V	575 V, 60 Hz, 4.05 lb-ft (5.5 Nm)	
4	71590533	1	Gearbox set DC10 V1		
4	71590633	1	Gearbox set DC10/20 V2		
4	71590733	1	Gearbox set DC20 V2		
5	71592033	1	Service hood set DC10/20	5.53 lb-ft (7.5 Nm)	
6	71592133	1	Electrical equipm.hood set DC10/20	7.00 lb-ft (9.5 Nm)	
8	71594733	1	Adjustment nut/pulse wheel		
9	71591933	1	Gear oil/seal/slipping clutch		
10	71598733	1	Chain collector box set 8m		
10	71598833	1	Chain collector box set Flex		
11	71596033	1	Chain set DC 5m 2/1	c/w item 12, 7.00 lb-ft (9.5 Nm)	
11	71596133	1	Chain set DC 8m 2/1	c/w item 12, 7.00 lb-ft (9.5 Nm)	
12	71595333	1	Buffer set	V1, V2	
13	71598533	1	Bottom block Set DC2/1	5.01 lb-ft (6.8 Nm)	
13	71598433	1	Bottom block Set DK2/1	5.01 lb-ft (6.8 Nm), (e.g. for hot applications)	
14	71597433	1	Suspension set		
15	77330033	1	Controller DSC		
16	71885633	1	Slide-in unit/plug		
19	71582033	1	Control set 400V	380 V - 415 V, 50 Hz, 2.21 lb-ft (3 Nm)	
19	71582133	1	Control set 460V	440 V - 480 V, 60 Hz, 2.21 lb-ft (3 Nm)	
19	71582333	1	Control set 575V	575 V, 60 Hz, 2.21 lb-ft (3 Nm)	
20	71881033	1	Control cable set 5m	7.74 lb-ft (10.5 Nm)	
20	71880933	1	Control cable set 8m	7.74 lb-ft (10.5 Nm)	
22	71588033	1	Limit switch set	2.21 lb-ft (3 Nm)	
23	71880433	1	Emergency-stop set/rubber cap DSC	Controller	
25	71582533	1	Contact set		

21474006.tbl

DCM 1, DCM 2, DCM 5

42652446.eps

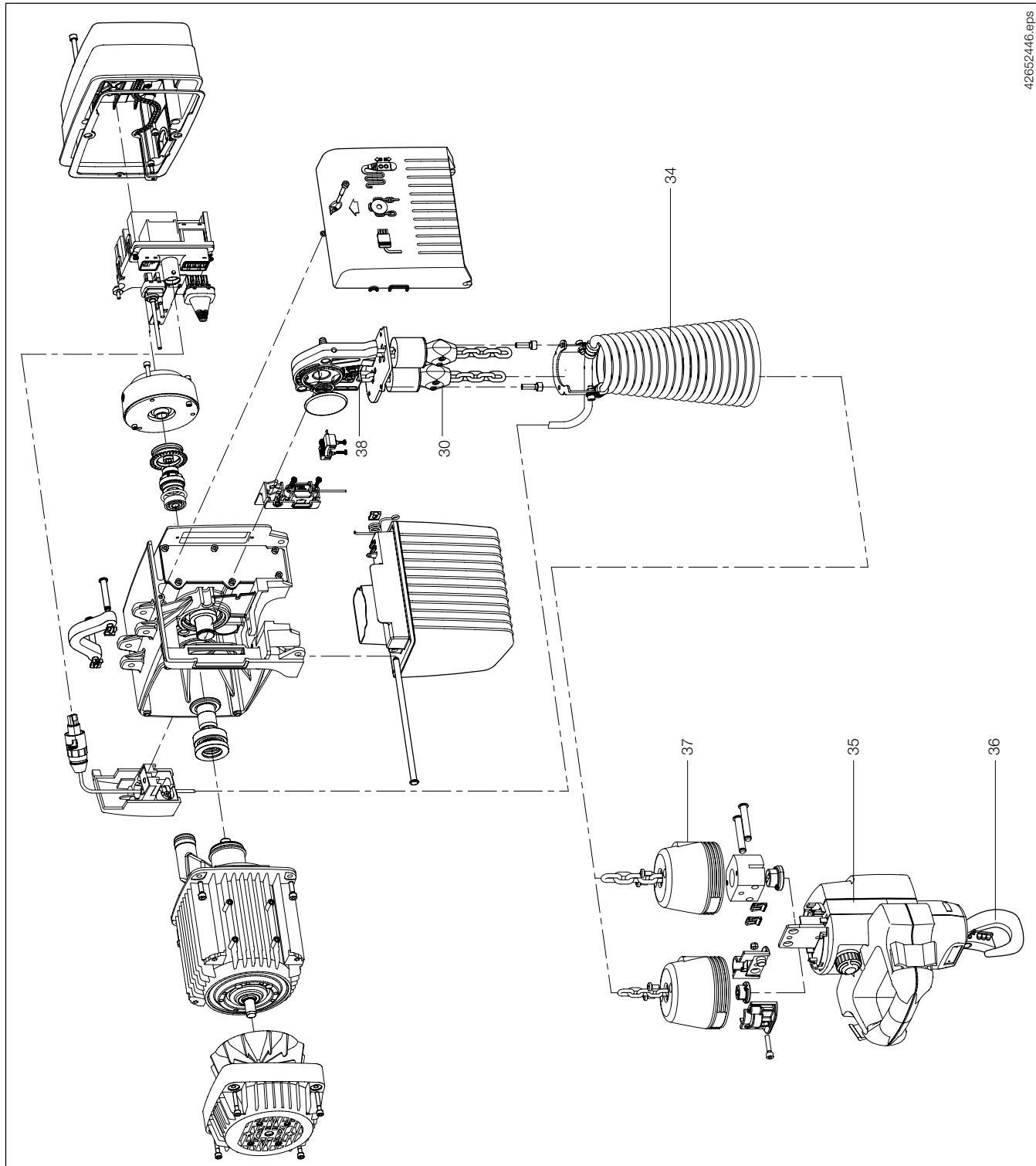

Item no.	Part no.	Quantity	Designation	Material	Standard
30	83508344	1	Stop piece DK 2		
30	83608344	1	Stop piece DK 5		
34	77345733	1	Helix cable KPL 2800		3.17 lb-ft (4,3 Nm)
34	77345933	1	Helix cable KPL 4300		3.17 lb-ft (4,3 Nm)
35	77348033	1	Control unit DSM-C		
36	83566544	1	Load hook DKDSM5 250KG		
37	71896033	1	Fixing set DCM 1-5		
38	71794833	1	Chain set 3,1m		DCM 1 + 2
38	71795033	1	Chain set DC1/DC2 5m		DCM 1 + 2
38	71894833	1	Chain set 3,1m		DCM 5
38	71895033	1	Chain set DC 5 5m		DCM 5

EC conformity declaration

Demag DC chain hoists
in accordance with EC directive 89/336/EEC, Annex I, 98/37/EU,
Annex II A and 73/23/EEC, Annex III

Hereby we,

Demag Cranes & Components



declare that the product

Demag DC, DCM chain hoist

of serial design ready for use¹⁾ with or without the relevant serial trolleys including the Demag serial accessories has been declared in conformity with the provisions of the following relevant regulations:

EC EMC directive	89/336/EEC
amended by	92/31/EEC, 93/68/EEC
EC Machinery Directive	98/37/EC
EC Low voltage Directive	73/23/EEC
amended by	93/68/EEC

Applied harmonised standards:

EN 292-1, 292-2	Safety of machinery
EN 818-7	Chains for hoist units, quality class T
EN 954-1	Safety related parts of control systems –General principles for design
EN 50178	Installation of electronic equipment in power systems
EN 60034-1	Rating and performance for rotating electrical machines
EN 60034-5	Types of enclosures for rotating electrical machines
EN 60204-32	Electrical equipment, requirements for hoists
EN 60529	Types of enclosure (IP code)
EN 60947-1	Low voltage switchgear, general rules
EN 61000-6-2	Electromagnetic compatibility –Immunity for industrial environments
EN 61000-6-3	Electromagnetic compatibility –Emission standard for residential, commercial and light-industrial environments
EN 61000-6-4	Electromagnetic compatibility –Emission standard for industrial environments

Applied standards and technical specifications:

FEM 9.511	Classification of mechanisms
FEM 9.683	Travel and hoist motor selection
FEM 9.751	Powered serial hoist units –safety
FEM 9.755	Measures for achieving safe working periods

Wetter, 01.12.2004

Place and date of issue

ppa. Gersemsky
Technik Handling Technology

ppa. Hoffmann
GZ Handling Technology

1) Hoist ready for service includes a scope of parts as specified in Works standard 012 313 99.

Sales and Service Centers in North America

California

5435 Industrial Parkway • San Bernardino, California 92407
Telephone: (909) 880-8800 • Fax: (909) 880-4469

Georgia

254 Lake Ruby Drive • Suwanee, Georgia 30024
Telephone: (678) 546-0593

Illinois

11261 Kiley Drive • Huntley, Illinois 60142
Telephone: (847) 515-7030 • Fax: (847) 515-7040

Michigan

24541 Maplehurst Drive • Clinton Township, Michigan 48036
Telephone: (810) 954-1000 • Fax: (810) 954-1001

Missouri

529 E. 5th Street • Washington, Missouri 63090
Telephone: (636) 390-2495 • Fax: (636) 390-0366

South Carolina

BTC 560, Suite 150, 454 S. Anderson Road • Rock Hill, SC 29730
Telephone: (803) 909-9000 • Fax: (803) 909-9001

Ohio

29201 Aurora Road • Cleveland, Ohio 44139
Telephone: (440) 248-2400 • Fax: (440) 248-3086

Ontario

1155 North Service Road West • Oakville, Ontario L6M 3E3
Telephone: (905) 825-5900 • Fax: (905) 825-5901

Quebec

3257 Pitfield Blvd • St-Laurent, Quebec H4S 1H3
Telephone: (514) 336-5556 • Fax: (514) 336-4349

Texas

16430 Aldine-Westfield Road • Houston, Texas 77032
Telephone: (281) 443-7331 • Fax: (281) 443-7308

Washington

16771 N.E. 80th Street, Suite 205 • Redmond, Washington 98052
Telephone: (425) 883-4668 • Fax: (425) 883-4828

Demag Cranes and Components

29201 Aurora Road
Cleveland, Ohio 44139
Telephone: (440) 248-2400
Fax: (440) 248-3086
Internet: <http://www.demag-us.com>