

Collectors

Current Collecting Components/Collectors



TranStech™
POWER TRANSFER SYSTEMS



**Collector Designs
for all Applications**

**Many different
Collector Interface
Materials & Styles**

**Rigid Conductor
Bar Collectors**

**Pick up Wire Collector
Designs**

**Self Aligning and
Tracking Collector
Designs**

**Collectors for Under,
Over and Side Running
Applications**

**Application Engineering
Available to Design
to Meet Customer
Specifications**

Moving Electrification *Forward*



V Bar System with Corrugated Standoff Insulators

Features

- Dual Collector Designs Available
- Carbon Contact Surfaces
- Incorporated Insulator Designs
- Multiple Shoe Designs with Custom Engineered Options Available
- Designs for Misalignment Correction both Vertical and Horizontal
- Designs for Rigid & Wire Conductors
- Tracking Shoe Options Available

Heavy Duty Current Collectors

Application

XVI Collectors are for pick-up wire conductor systems, mainly used on overhead crane bridges to collect current from the trolley wire conductor system to run the transverse movement or lifting motors of the crane. These collectors are suitable for all sizes of trolley wire up to and including 3/0 B & S.

Features

The XVI Collector consists of an aluminum or brass body made in two halves which retains the contact member. This type of collector provides a self-cleaning and lubricating action which maintains a burnished conductor wire assuring longer life.

On critical circuits to assure continuity of service or where dirt contamination is prevalent, collectors in tandem are recommended. When using the square bar mounting, a single bracket assembly supports two collectors in tandem, however when using collectors with insulator mounting for the same purpose, two collectors are mounted together to suit the customer's mounting conditions.

Special Features

Body - Two types

- Aluminum -recommended for indoor service.
- Brass -recommended for outdoor service or where excessive industrial contamination prevails.

Terminal mounting holes are provided as shown on drawings.

Mounting - Two types

- Composition insulator with integrated molded shaft and tapped boss.
- Bracket for square bar mounting. In this type the insulation is provided by the customer's mounting which normally consists of a square bar covered with an insulating tube. Brackets are designed for mounting on square bars including insulation from 1" to 1 1/2". It is necessary when ordering to specify the size bar used including the insulation.

Removable Contact Members

Accurately machined grooved blocks to secure maximum transfer or current. They can easily be replaced by loosening two screws in the body assembly. Furnished in two capacities.

- Standard (Electro Graphite Carbon) - 35 to 75 amperes approximate continuous rating depending upon working conditions.
- High Capacity (Metal Graphite) - 75 to 125 amperes approximate continuous rating depending upon working conditions.

Collector Unit with Threaded Stud

This unit is supplied for replacement or where user supplies the insulator. For this application the collector unit is equipped with a special shaft threaded 1/2" - 13 and supplied with a jam nut.

Project Engineering and On-Site Installation Support

TransTech's engineers custom-configure our products and systems to meet each customer's unique application requirements. We provide on-site technical installation support and layout drawings to our customers and their installation teams.

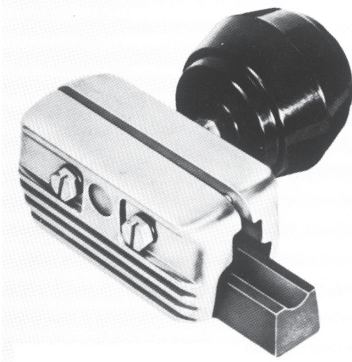

XVI Collector with Insulator Mounting showing the contact member partly removed

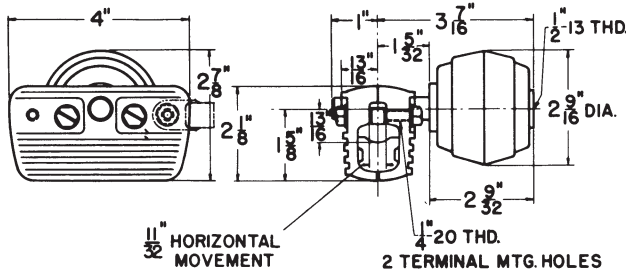

Single XVI with Insulator Mounting

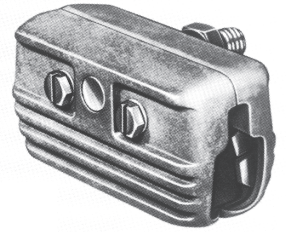

XVI Collector Unit with Threaded Stud

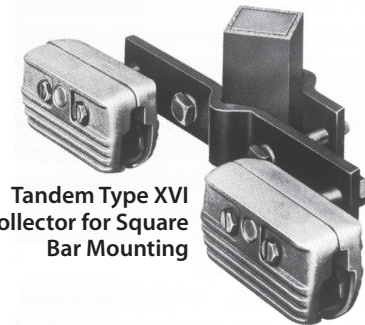

Tandem Type XVI Collector for Square Bar Mounting

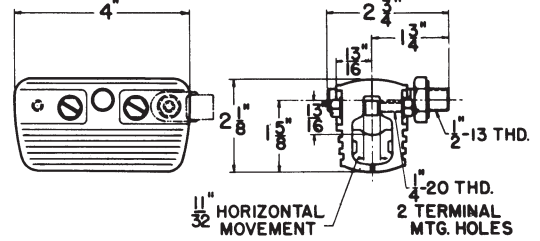

Collector Unit only with Threaded Stud

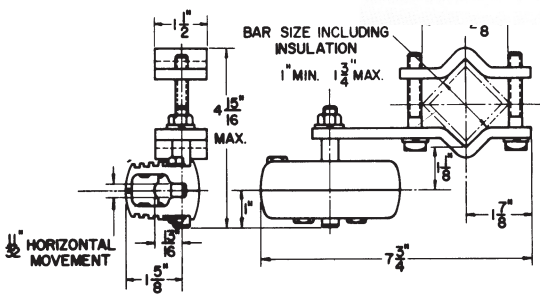

Single XVI with Square Bar Mounting

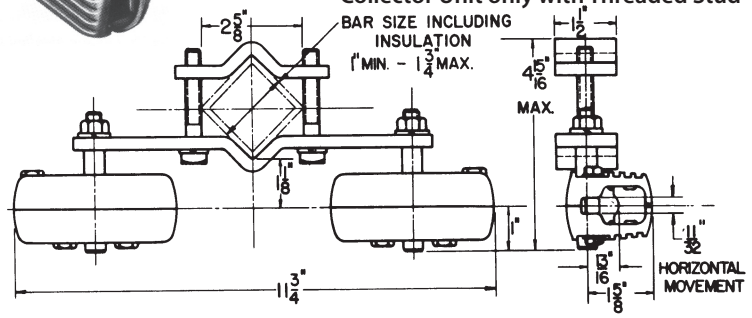

Double XVI with Square Bar Mounting

Catalog Information

Style of Mounting	Collector	Body	Contact	Contact Number	*Approx. Continuous Current Capacity Amperes	Net Wt. Each Lbs.	Catalog Number
Insulator	Single	Alum.	Standard	88321	35 - 75	1.50	88804
Insulator	Single	Alum.	High Capacity	88597	75 - 125	1.80	88595
Insulator	Single	Brass	Standard	88321	35 - 75	2.75	88825
Insulator	Single	Brass	High Capacity	88597	75 - 125	3.05	91554
Square Bar	Single	Alum.	Standard	88321	35 - 75	2.45	93828
Square Bar	Double	Alum.	Standard	88321	70 - 150	3.70	93382
Square Bar	Single	Alum.	High Capacity	88597	75 - 125	2.75	93829
Square Bar	Double	Alum.	High Capacity	88597	150 - 250	4.40	93830
Square Bar	Single	Brass	Standard	88321	35 - 75	3.75	98390
Square Bar	Double	Brass	Standard	88321	70 - 150	6.35	98367
Square Bar	Single	Brass	High Capacity	88597	75 - 125	4.05	98391
Square Bar	Double	Brass	High Capacity	88597	150 - 250	7.00	98368
1/2" Threaded Stud	Single	Alum.	Standard	88321	35 - 75	1.0	88803
1/2" Threaded Stud	Single	Alum.	High Capacity	88597	75 - 125	1.3	88596
1/2" Threaded Stud	Single	Brass	Standard	88321	35 - 75	2.25	90428
1/2" Threaded Stud	Single	Brass	High Capacity	88597	75 - 125	2.55	92422
Standard Renewable contact only						.13	88321
High Capacity Renewable contact only						.44	88597

* This rating is necessarily approximate due to changes in working conditions

Ordering Directions: Specify by catalog number.

On bar mounted collectors, specify bar size when ordering, from 1" to 1 3/4" including insulation.

**Collectors - Pick-Up
Type XVE, BV, BW, PW**

Application

Four types of "Pick-up" collectors illustrated are mainly used on overhead crane bridges to collect current from the trolley conductor system to run the transverse movement or lifting motors of the crane.

The XVE collectors are "pick-up" wire conductor systems where the runs are comparatively short and current requirements are low.

These collectors are suitable for all sizes up to and including #3/0 B & S trolley conductors.

Features

Contact members of the type XVE is a grooved carbon insert bonded to a copper plated steel body and can be quickly removed and replaced by means of a cotter pin. Terminal connections can be made to the holes on either side of the body. Short height of this unit permits close spacing of the trolley wire conductors.

BV, BW, and PW contact members are either bronze wheels or shoes, the sliding shoe type of contact being preferred where there is dust and dirt because of its self-cleaning action.

Types BV and BW have a molded composition insulator with an integrally molded shaft while the PW is furnished with a porcelain corrugated insulator.

Type BW is constructed with two contact wheels mounted on a frame to provide a higher capacity positive contact with the conductor wire. Its compactness permits close spacing of conductors.

Type PW with porcelain corrugated insulator provides better insulation, particularly for outdoor service.

Type BV has sliding contact providing self-cleaning action. It is compact, permitting close spacing of conductors.

Type XVE collector consists of insulator with an integrally molded shaft supporting an inexpensive replaceable contact.

Type XVE

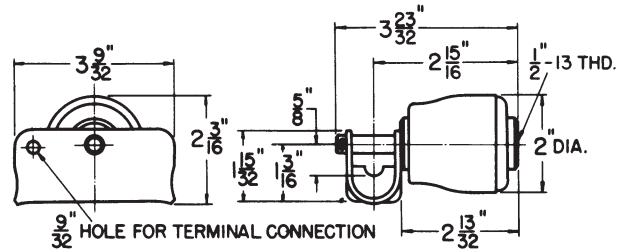
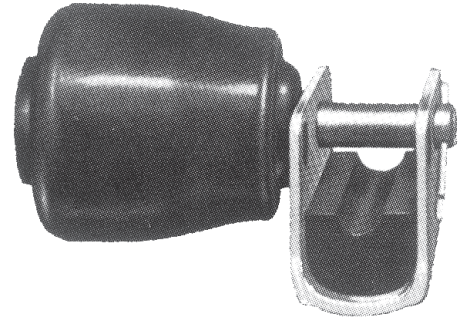

Type XVE collector consists of insulator with an integrally molded shaft supporting an inexpensive replaceable contact.

Type BW

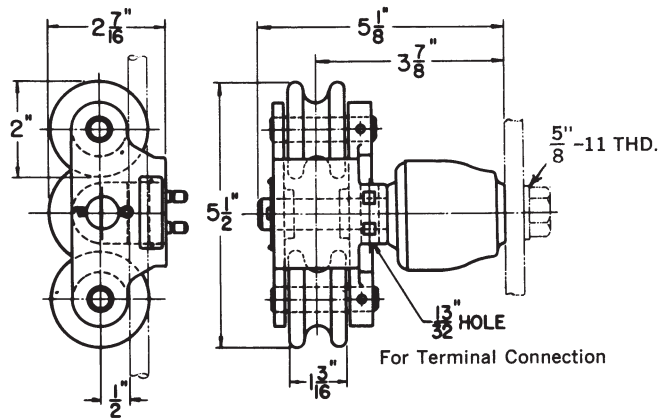
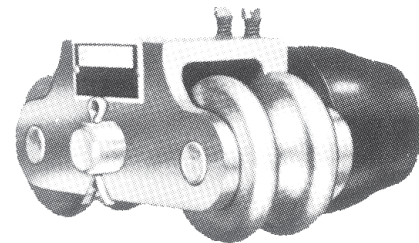

Type BW with two contact wheels mounted on a frame to provide a higher capacity and positive contact with the conductor wire. Its compactness permits close spacing of conductors.

**Collectors - Pick-Up
Type XVE, BV, BW, PW**

Type BV

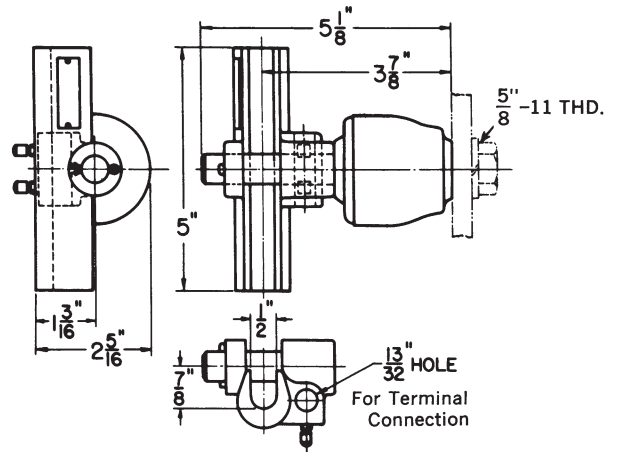
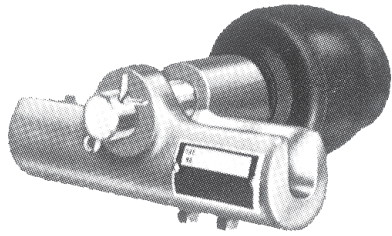

Type BV with sliding contact provides self-cleaning action, its compactness permits close spacing of conductors.

Type PW

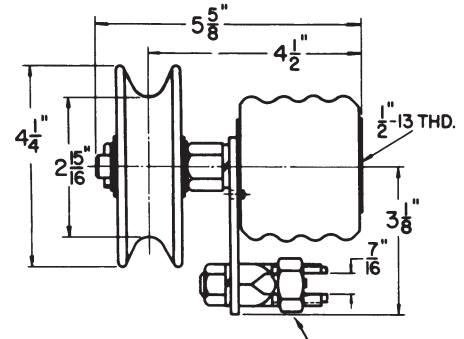
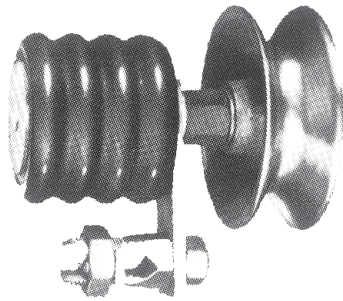

Connector
Range up to 3/0 Solid and 2/0 Standard Max.

Type PW with porcelain corrugated insulator provides better insulation, particularly for outdoor service.

Catalog Information				
Description	Contact Number	*Approx. Current Capacity Amperes	Net Wt. Each Lbs.	Catalog Number
XVE Complete	93824	35	.90	93820
Replaceable Contact	---	35	.45	93824
BV Collector Complete	46615	100	3	46491
BW Collector Complete	46488	75	4.75	46492
PW Collector Complete	18897	75	5	70545

*This rating is approximate due to changes in working conditions.

Ordering Directions

Specify by catalog number.

Collectors - Arm Type "Junior" Series

Application

"Junior" series of wire or rigid type conductor collectors illustrated are designed for light crane indoor operation with service characteristics as listed. This is the "Junior" series of a group of collectors including the "Universal" and "Pantograph" type for wire or rigid conductor applications.

Features

"Junior" collectors consist of a malleable iron arm and mounting assembly with either bronze wheels or shoes as contact members. Compression spring in the mounting assembly maintains pressure for contact with the conductor.

Arm can swivel 360° so that the collector can be positioned to meet space and mounting conditions. This is also of value in allowing for some misalignment of the conductor.

Insulation is provided by either a giant strain insulator or a square mica tube bushing depending upon the type of mounting.

Provision for feeder connections are provided direct to the contact shoe or to the mounting body in the wheel types.

Installation of collectors in parallel on the same conductor is recommended in order to assure maximum efficiency and insure continuous contact. This is particularly desirable on control circuits or in contaminated areas where dirt build-up reduces contact efficiency.

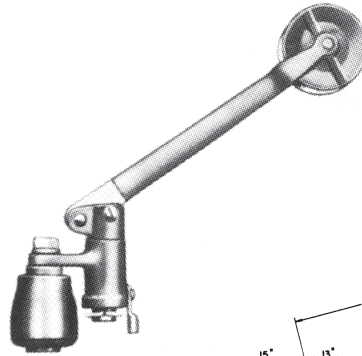

60036
Collector with grooved wheel and giant strain insulator mounting

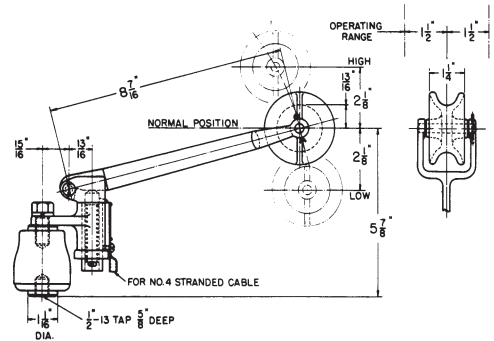

60141
Collector with grooved wheel and insulated square bar mounting

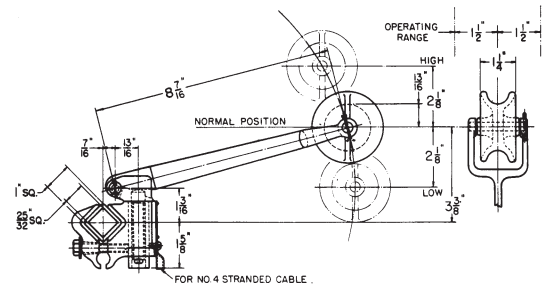

**Collectors - Arm Type
"Junior" Series**

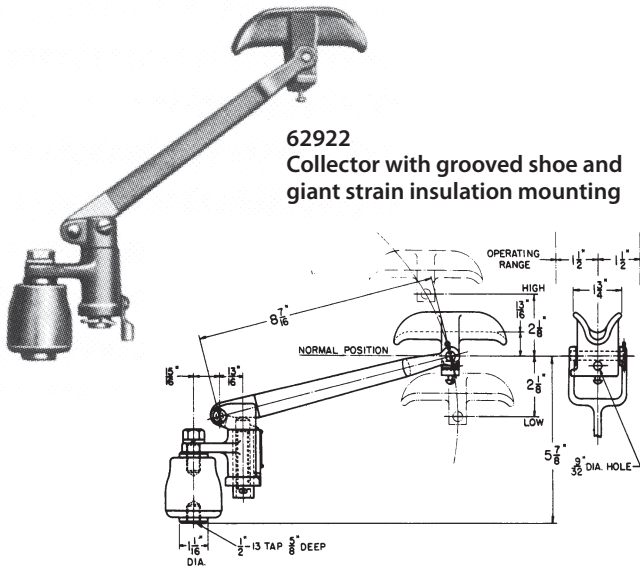

62922
Collector with grooved shoe and
giant strain insulation mounting

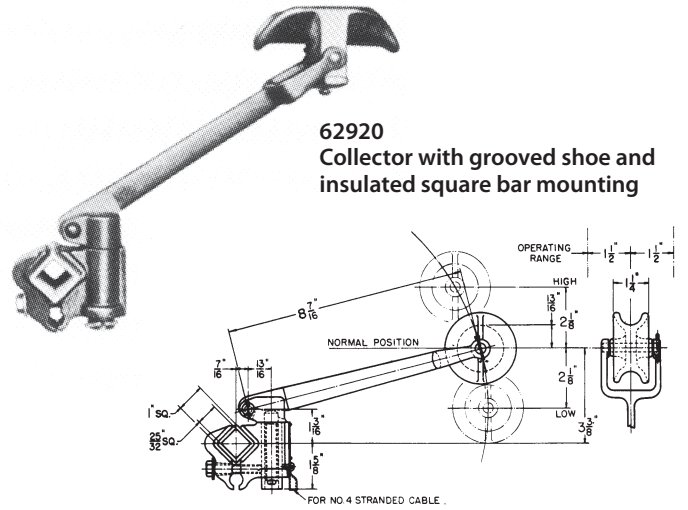

62920
Collector with grooved shoe and
insulated square bar mounting

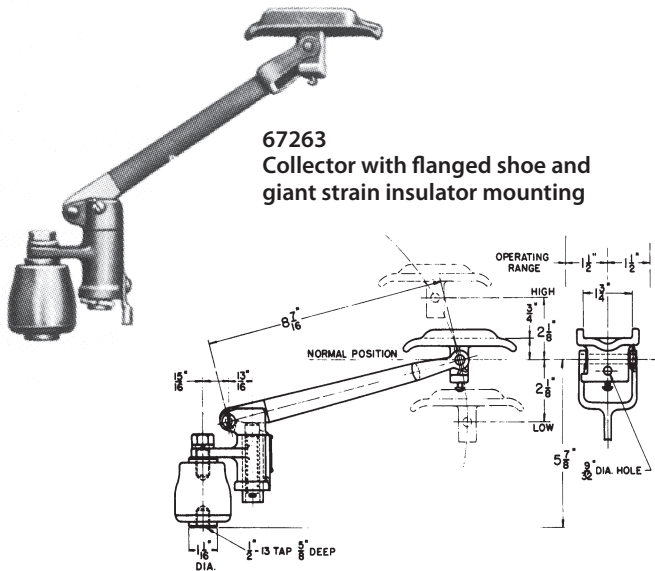

67263
Collector with flanged shoe and
giant strain insulator mounting

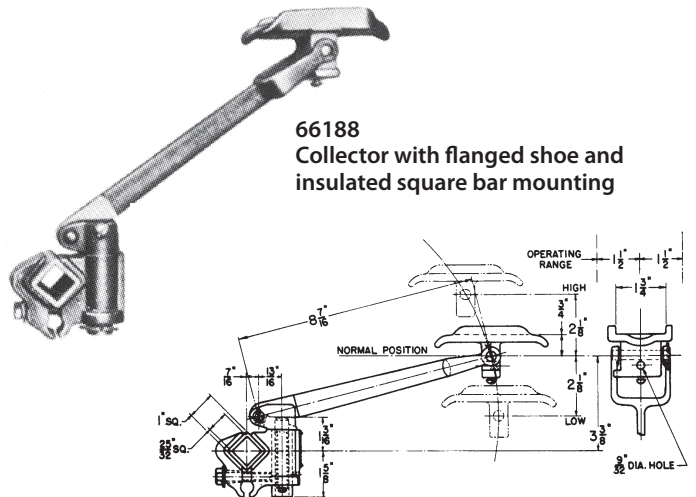

66188
Collector with flanged shoe and
insulated square bar mounting

Catalog Information

Description	Type of Mounting	Contact Member	*Approx. Current Capacity Amperes	Maximum Service Rating Volts	Net Wt. Each Lbs.	Catalog Number
Type JAW	Insulator	60047 — 2 1/2" Bronze Wheel	40	750	3.50	60036
Type JBW	Square Bar	60047 — 2 1/2" Bronze Wheel	40	750	3.50	60141
Type JAS	Insulator	62918 — Bronze Shoe	75	440	3.50	62922
Type JBS	Square Bar	62918 — Bronze Shoe	75	440	3.50	62920
Type JAF	Insulator	62918 — Bronze Shoe	75	750	3.50	67263
Type JBF	Square Bar	62918 — Bronze Shoe	75	440	3.25	66188

* Current carrying capacities are approximate as they depend upon conditions of installation such as speed, contact pressures, frequency of use, cleanliness of contact surfaces, etc.

Ordering Directions - Specify by catalog number.

Collectors - Arm Type "Universal Series"

Application

"Universal" collectors are used for many conductor systems as required on crane bridge or main runways or similar applications. Designation "Universal" refers to the design which, by combining parts, provides mountings and contacts to meet varying conditions. Collectors shown are considered as standard, however other assemblies are available, made to order, such as collectors with porcelain insulators, bronze contacts, other width contacts, without insulators, etc.

Features

Collector consists of cast iron and aluminum arm assembly with mounting and various shapes of shoes or wheels as contact members. Strong adjustable compression spring maintains the proper pressure of the contact member with the conductor depending upon operating conditions.

Feeder connections are made to the contact member of the shoe types or to the arm of wheel types. Horizontally mounted collectors shown have swivel bases to compensate for a certain degree of misalignment of the conductor wire. Vertically mounted collectors have a rigid base but the wheel has an extending shaft for side movement in case of misalignment.

Two Red-Poly insulators are normally supplied for mounting, however where excessive moisture or industrial contamination are prevalent, porcelain insulators can be supplied with a larger mounting base, made to order.

Dual installation of collectors connected in parallel on the same conductor is recommended in order to assure maximum efficiency and insure continuous contact. This

is particularly desirable on control circuits or in contaminated areas where dirt build-up reduces contact efficiency.

Collectors having flat shoe contacts with or without flanges have a cleaning groove to allow dirt contamination to drop away and are furnished with two special composition inserts achieving a lubricating and burnishing action on the conductor.

Catalog No's 46199 and 46211 collectors are supplied with high quality bronze: wheels and are normally used on systems of low current ratings.

Catalog No. 93148 collectors have a grooved bronze sliding contact furnishing a self-cleaning action together with a greater contact surface.

Catalog No's 92944 and 94136 have a grooved bronze sliding contact with two special composition inserts achieving a lubricating and burnishing action on the conductor wire. Inserts are furnished in two ratings, the "Standard" and the "High Capacity" with values as shown in the tabular listing on the following page.

Catalog No's 94058 and 94059 collectors have a cast iron arm provided with a ball that fits a socket in the shoe thus providing considerable movement of shoe in case of conductor misalignment. The long cast iron shoe has a large cleaning groove. This shoe provides two contact surfaces, fitting the inside of an inverted angle conductor.

Catalog No. 46227 collector is provided with a bronze flanged wheel for use on a narrow tee or bar conductors.

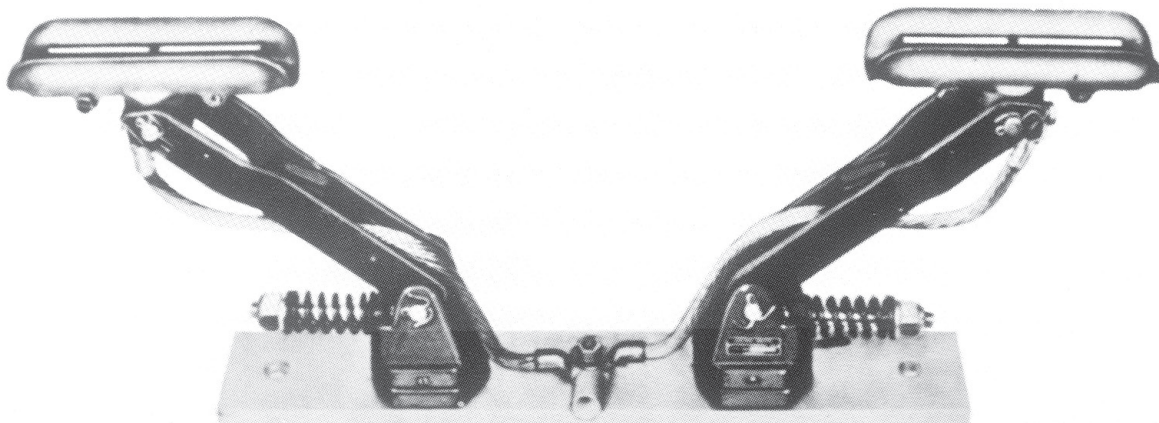

Typical arrangement of collectors in parallel

***Collectors - Arm Type
"Universal Series"***



46199
Collector with horizontal mounting and bronze wheel contact.

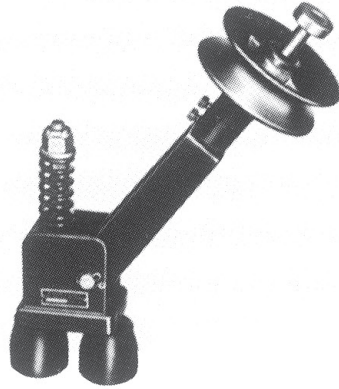

46211
Collector with vertical mounting and bronze wheel contact.



93148
Collector with horizontal mounting and bronze sliding contact.



92944 or 94136
Collector with horizontal mounting and sliding contact with standard or high capacity inserts.



94106
Collector with horizontal mounting and cast iron grooved contact shoe with inserts.

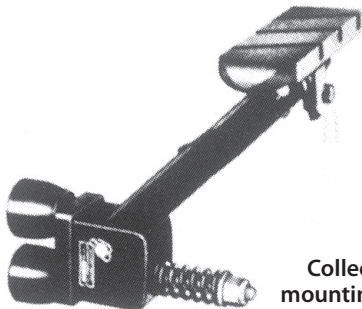

46192
Collector with vertical mounting and cast iron flat contact shoe with inserts.

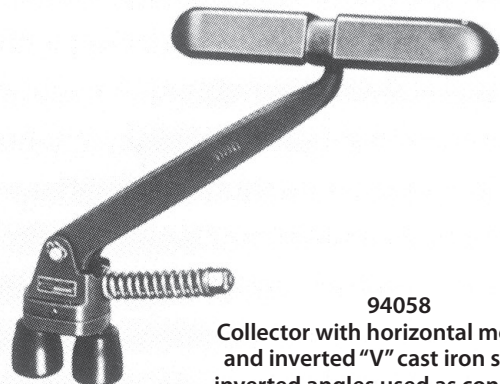

94058
Collector with horizontal mounting and inverted "V" cast iron shoe for inverted angles used as conductors.

Collectors - Arm Type
"Universal Series"

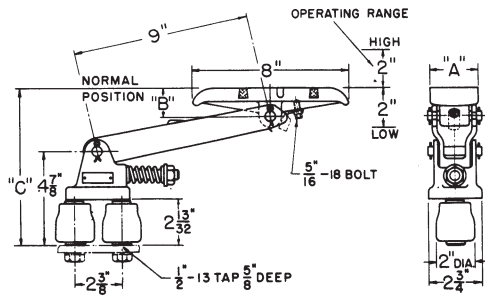

	A	B	C
92868 with 1 1/4" wide shoe	1 1/4	1 3/14	9 3/16
94060 with 2 1/3" wide shoe	2 1/2	1 1/2	9 3/8

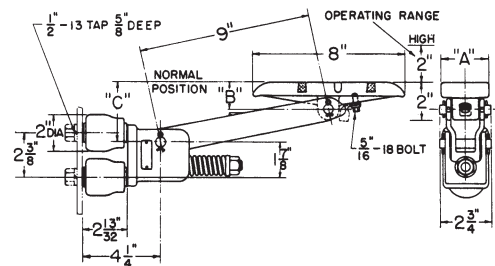

	A	B	C
94102 with 1 1/4" wide shoe	1 1/4	1 3/14	4 3/16
94103 with 2 1/3" wide shoe	2 1/2	1 1/2	4 3/8

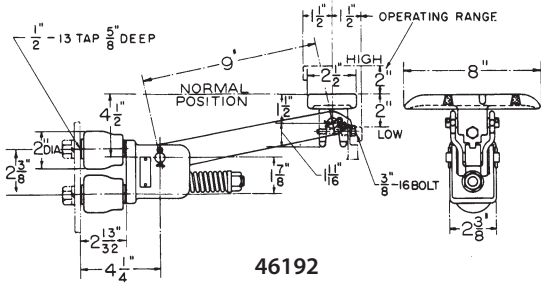

46192

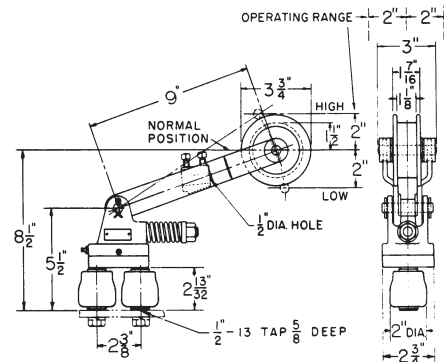

46227

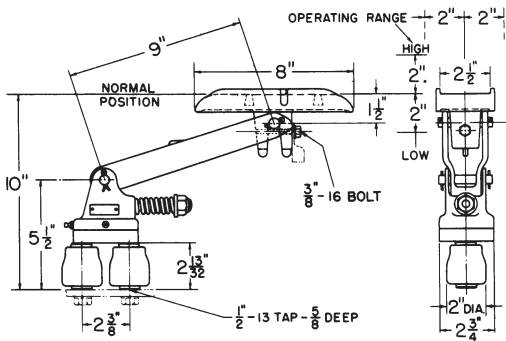

94106

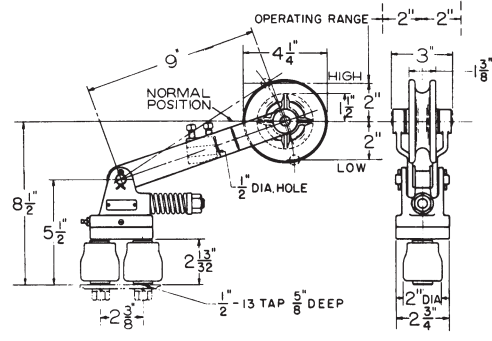

46199

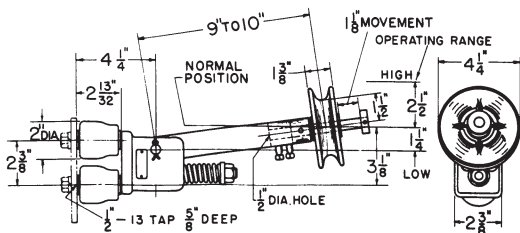

46211

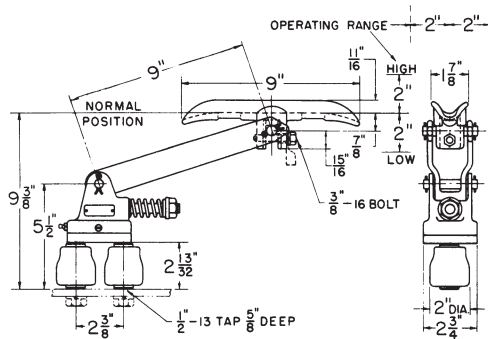

93148

Collectors - Arm Type
"Universal Series"

92944
94136

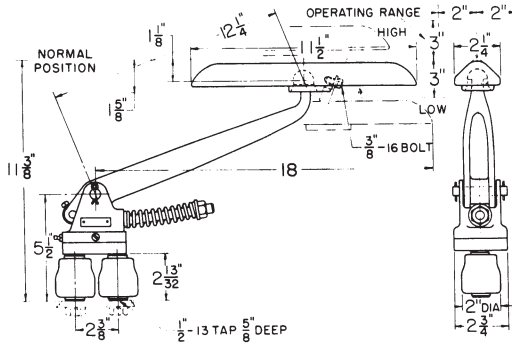
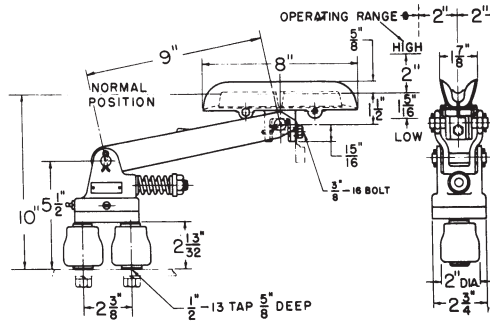

94058

Used with 2" and 2 1/2" Angles.

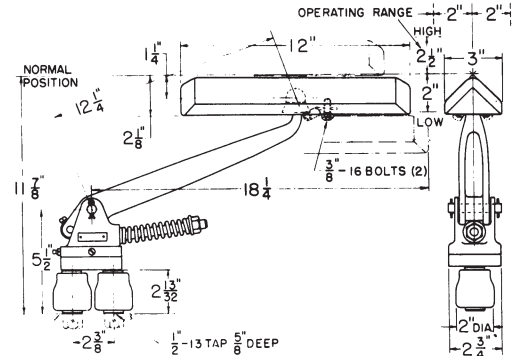

94059

Used with 3" and 4" Angles.

Catalog Information

Description	Width of Contact Inches	Contact Number	Distance from Mounting Surface to Conductor Inches	*Approx. Current Capacity Amperes	Maximum Service Rating Volts	Net Wt. Each Lbs.	Catalog Number
Collector - Horizontal Mounting Bronze Wheel		18897	10	75	750	11	46199
Collector - Vertical Mounting Bronze Wheel		18897	See Drawing on page 9	75	750	9 1/2	46211
Collector - Horizontal Mounting Bronze Siding Contact		94657	9 3/8	150	750	11 1/4	93148
Collector - Horizontal Mounting Sliding Contact & Standard Inserts		94658	10	150	750	11	92944
Collector - Horizontal Mounting Sliding Contact & High Capacity Inserts		94661	10	200	750	11 1/2	94136
Collector - Horizontal Mounting Flat Iron Shoe with Inserts	1 1/4	94770	9 3/16	75	750	9	92868
Collector - Horizontal Mounting Flat Iron Shoe with Inserts	2 1/2	94654	9 3/8	125	750	11	94060
Collector - Vertical Mounting Flat Iron Shoe with Inserts	1 1/4	94770	See Drawing on page 9	75	750	10 1/2	94102
Collector - Vertical Mounting Flat Iron Shoe with Inserts	2 1/2	94654	See Drawing on page 9	125	750	11 1/2	94103
Collector - Vertical Mounting Flat Shoe with Inserts	2 1/2	93121	See Drawing on page 9	125	750	11 1/2	46192
Collector - Horizontal Mounting Flanged Bronze Wheel	1 1/8	46162	10	100	750	11 1/4	46227
Collector - Horizontal Mounting Flanged Iron Shoe with Inserts	2 1/2	94660	10	125	750	13	94106
Collector - Horizontal Mounting Inverted V Shoe - Ball & Socket Design		94659	See Drawing Above	150	750	12 1/2	94058
Collector - Horizontal Mounting Inverted V Shoe - Ball & Socket Design		94094	See Drawing Above	150	750	15 3/4	94059

*Current carrying capacities are approximate as they depend upon conditions of installation such as speed, contact pressure, frequency of use, cleanliness of surfaces, etc.

Collectors - Pantograph Wire Conductor Series

Application

Pantograph Collectors with wheels are used on trolley wire conductor systems for slow-speed industrial cranes, particularly where there is much vertical misalignment in the installation.

Type	Height in normal working position	Range of Movement	
		Up	Down
SW	11 1/2"	3 5/8"	3"
KWL	16"	4"	5"

Features

Collector consists principally of malleable iron parts, the two lower arms being geared together at the base and controlled by a single adjustable tension spring assuring uniform pressure of the wheel on the conductor wire when running in either direction. In addition to the vertical movement, the entire pantograph is hinged at the base in order to give a slight horizontal movement to compensate for some misalignment in the conductor wire. Contact wheels are high quality bronze, 4 1/4" diameter in the Type SW and 8" diameter in type KWL. Large 8" wheel, obviously provides greater contact wearing surface and less tendency to leave the wire.

Feeder connections can be made to either or both of the upper arms in holes provided with set screws for securing the cable.

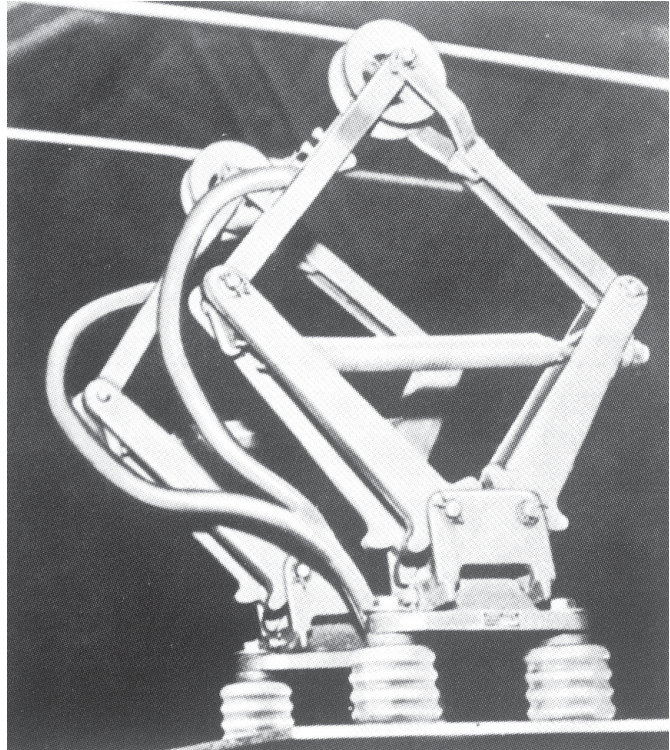

Typical Application of two pantographs in service

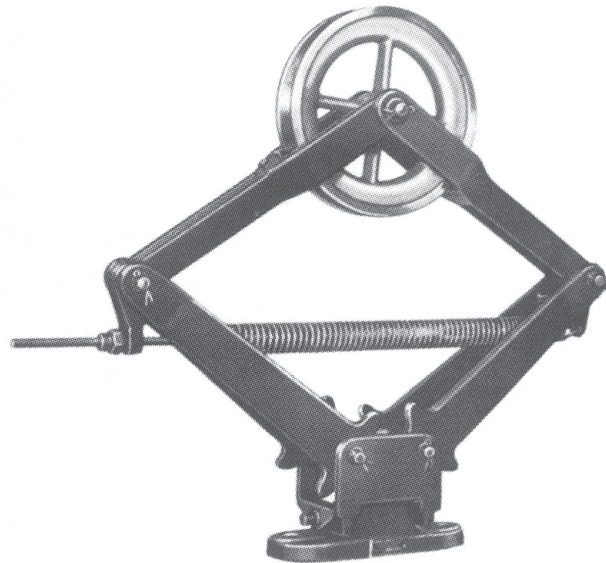

Type "KWL"

**Collectors - Pantograph
Wire Conductor Series**

46516

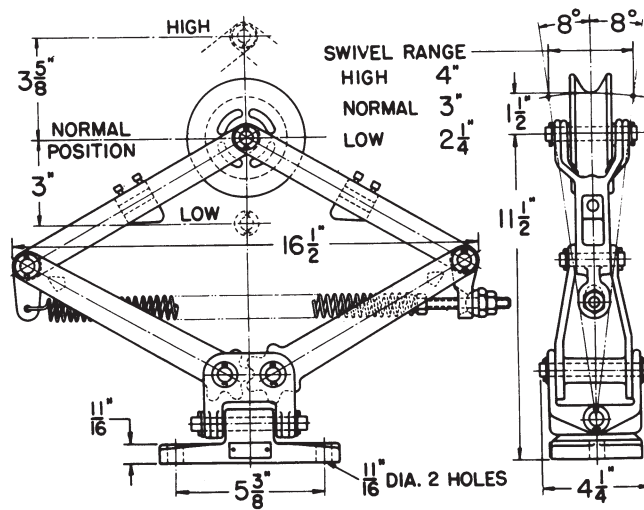

70086

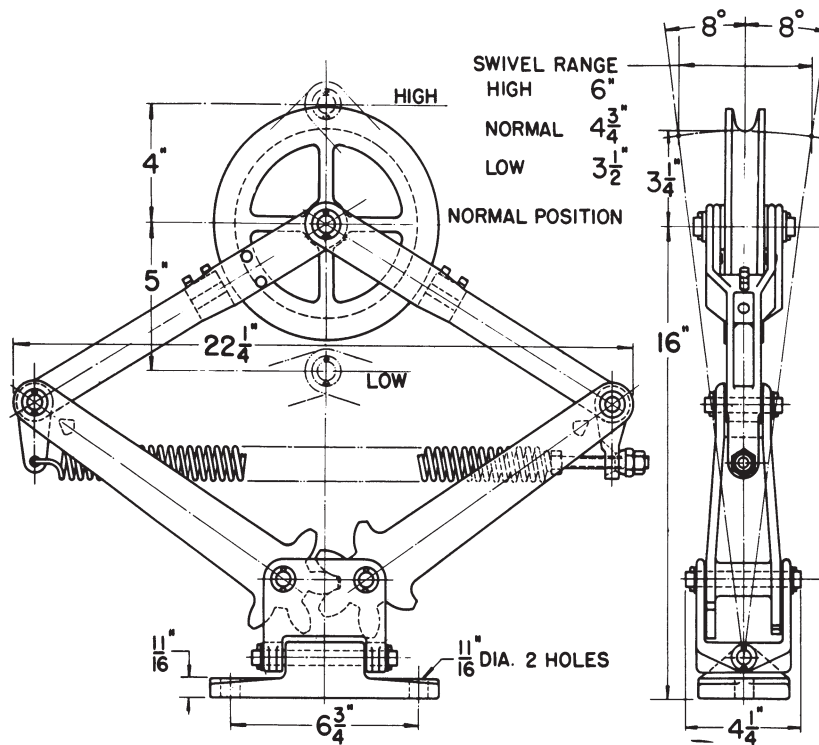

Catalog Information

Description	Contact Wheel Number	*Approx. Current Capacity Amperes	Approx. Wt. Each — Lbs.	Catalog Number
Pantograph Collector Type SW — 4 1/4"	18897	75	17	46516
Pantograph Collector Type KWL — 8" Wheel	48384	125	37	70086

* This rating is approximate due to changes in working conditions.

Ordering Directions - Specify by Catalog Number.

Collectors - Pantograph Rigid Conductor Series

Application

Pantograph Collectors with shoes are used with rigid conductors such as angles, tees and bars on collector systems for slow-speed industrial cranes, particularly where there is much vertical misalignment in the installation.

Type	Height in normal working position	Range of Movement	
		Up	Down
SA	11 ⁷ / ₈ "	3 ⁵ / ₈ "	3"
KA	16 ¹ / ₄ "	4"	5"

Features

Collector consists principally of malleable iron parts, the two lower arms being geared together at the base and controlled by a single adjustable tension spring assuring uniform pressure of the contact member on the conductor when running in either direction. Cast iron shoe with carbon inserts used in #46628 and 48287 pantograph collectors has a contact surface of 2¹/₂" x 6" but when equipped with the steel plate assembly the contact surface is increased to 5" x 8". Where there is considerable arcing necessitating more frequent replacement of the contact and excessive horizontal misalignment of the conductor bar, the use of the steel plate is recommended.

Feeder connections in the #46628 and 48287 pantographs are provided by means of a terminal attached to the contact member. Similar connections in #48480 and 48271 pantographs are made to a 1/2" hole with set screws to the casting supporting the contact plate.

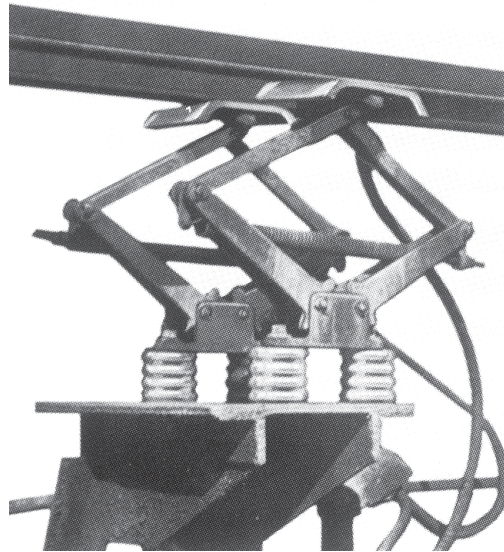

Pantograph with contact plate assembly

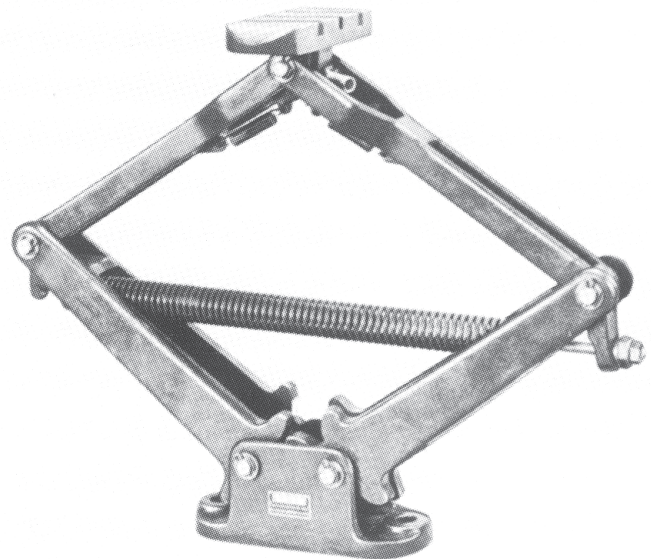

Type "KA"

Collectors - Pantograph Rigid Conductor Series

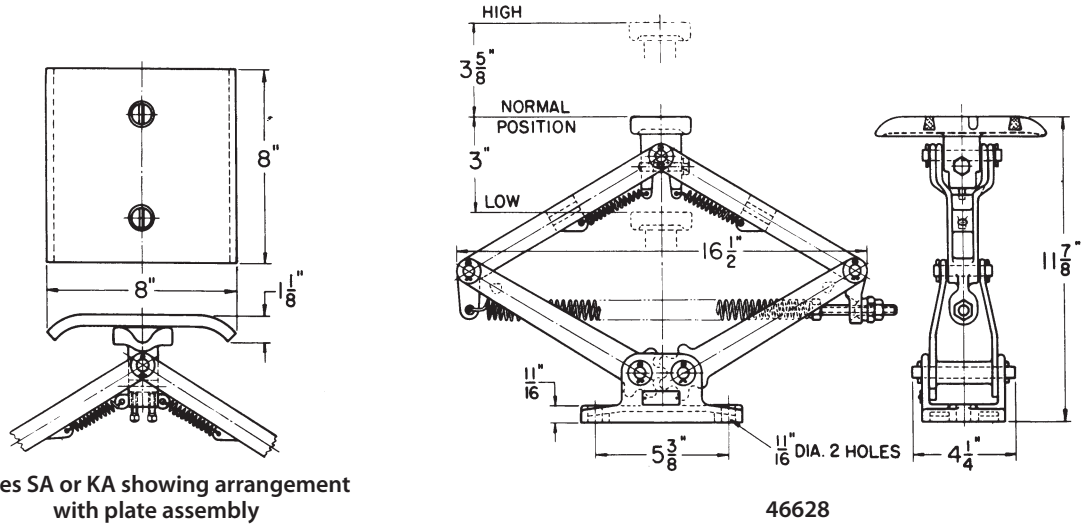

Types SA or KA showing arrangement with plate assembly

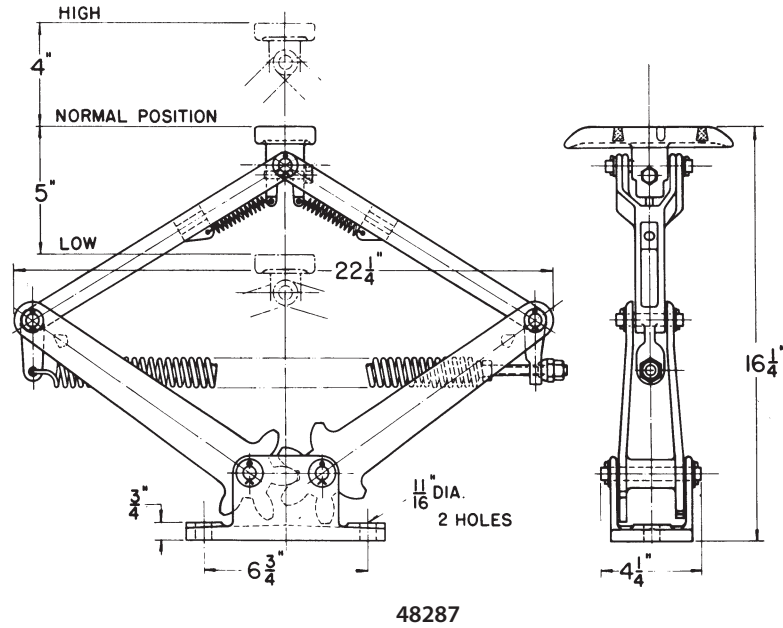

Catalog Information

Description	Contact Number	*Approx. Current Capacity Amperes	Approx. Wt. Each — Lbs.	Catalog Number
Pantograph Collector Type SA — with shoe	93121 — Shoe	125	17	46628
Pantograph Collector Type SA — with plate	48272 — Plate 48321 — Shoe	125	27	48480
Pantograph Collector Type KA — with shoe	93121 — Shoe	125	29	48287
Pantograph Collector Type KA — with plate	48272 — Plate 48321 — Shoe	125	39	48271

* This rating is approximate due to variations in operating conditions, but is based on employing full contact surface.

Ordering Directions - Specify by Catalog Number.

Collectors - Shoe Type For Rigid Conductors

Application

LMI, LM and LMV Collectors listed on the following pages are of the heavy duty type for use on conductor systems with rigid conductors as used on crane runways and similar installations. Under-running is preferable in installations subject to sleet, snow and dirt conditions.

In areas of excessive dirt contamination, the Type LMV Collector used with an inverted angle conductor is recommended.

Individual types vary in size and style of contact member.

Features

Collectors consist of an assembly of a vertical mounting frame plus a spring loaded arm supporting the contact member. Adjustable spring assures proper contact with the conductor and may be varied to meet the particular working conditions.

Types LMI, LM Pony and LM Standard are assembled in the factory for either overrunning or underrunning service. Correct catalog number should be selected from the listing shown on the following pages. Mounting frame is provided with a corrugated surface around an elongated slot interlocking with a corrugated washer for vertical adjustment.

Feeder connections are made to a bronze solderless connector on the mounting frame. Flexible copper cable connects the terminal lug and the contact member, thus bridging and bonding the hinged portion.

Replaceable contact member on all styles with the exception of the LMV, are reversible, thereby providing increased life. These contact members have a swiveling action to allow for any slight misalignment in the conductor.

Replaceable contact members and insulators for mounting these collectors are available. A Polyester fiberglass insulator is generally preferred for this application. Comparative features of each series are shown on page 21.

LMV Pony
Generally used on the following conductors:
2" or 2 1/2" angles

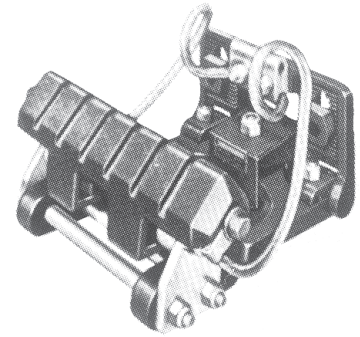

LM Pony
Generally used on the following conductors:
tees and angles
30 lbs. rail or under

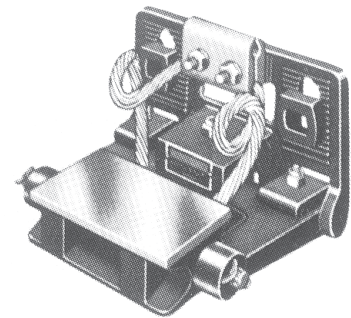

LMI Pony
Generally used on the following conductors:
tees and angles
30 lb. rails or under

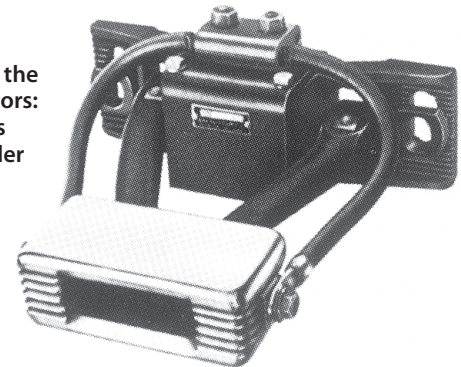

LM Standard
Generally used on the following conductors:
tees and angles
40 lbs. rail or above

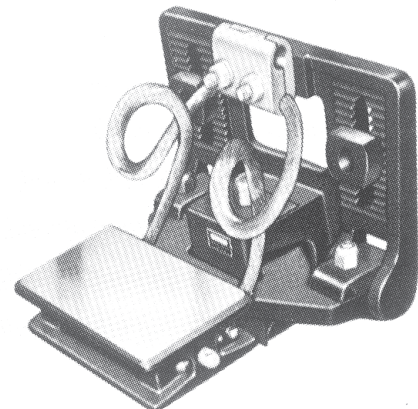

**Collectors - Shoe Type
For Rigid Conductors
LMV Pony Size**

Features

LMV Collectors are designed for use where the contact rail consists of an inverted "V" angle, either 2" x 2" or 2 1/2" x 2 1/2". Contact members are provided with self cleaning grooves so much of any foreign matter accumulating will be dislodged and will drop away from the contact surface. 98669 LMV collector is provided with a contact member which allows a horizontal movement of 1" for misalignment of the conductor. 98911 is similar in design except it is provided with an added plate construction, so arranged to provide a 2" horizontal movement where excessive misalignment of the conductor system is encountered.

**LMV Pony Size
(Underrunning)
98669**

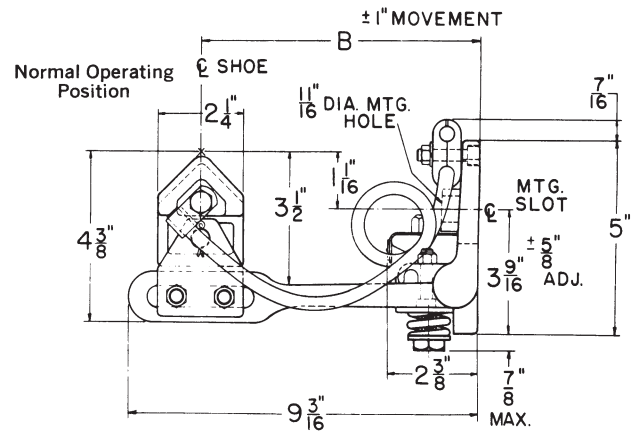
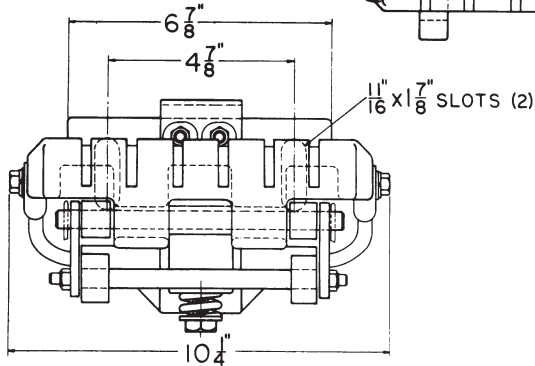
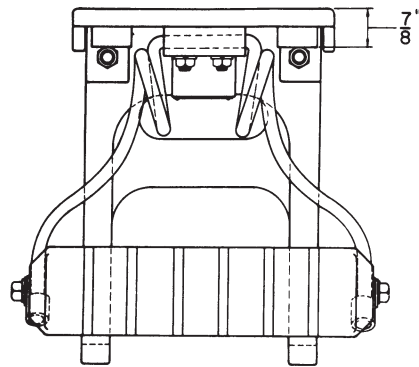
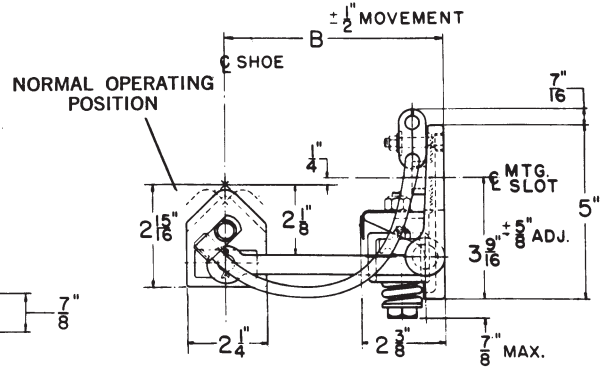
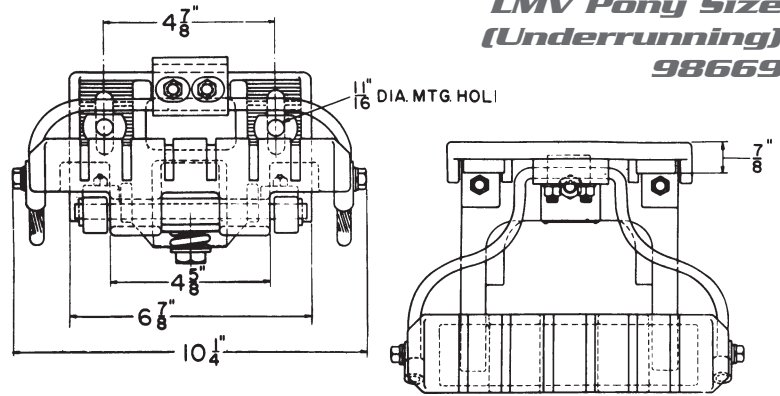

**LMV Pony Size (Underrunning)
98911**

Catalog Information

Description	Extension B	Horizontal Movement	Contact Member	*Range		Net Wt. Each — Lbs.	Catalog Number
				Up	Down		
LMV Collector — Underrunning	6 1/8"	1"	92930	3/4"	1 3/8"	14.25	98669
LMV Collector — Underrunning	7 3/8"	1 5/8"	92930	1"	1 5/8"	17.75	98911

* Range measurements apply to the vertical range with the collector in a horizontal position and measured from the point at the center of the member.

† When ordering, specify by catalog number.

**Collectors - Shoe Type
For Rigid Conductors
LMI Pony Size**

Features

LMI Collector has been designed with a short overall height to conserve vertical space in multiple collector installations. Open center design and fins provide a large radiating surface, high overload capacity and a minimum of weight moving part.

LMI Pony Size
95659 (Overrunning)
95660 (Underrunning)

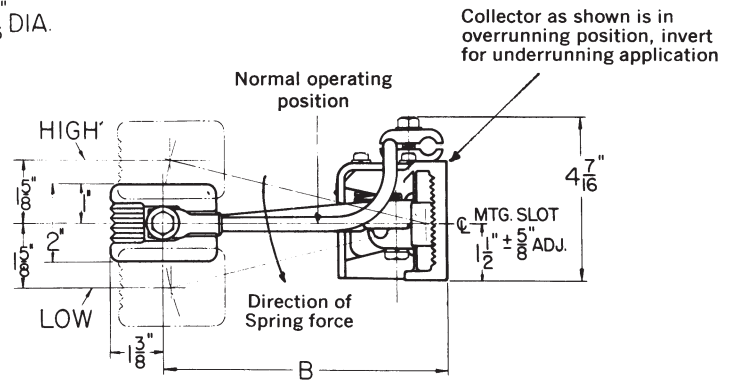
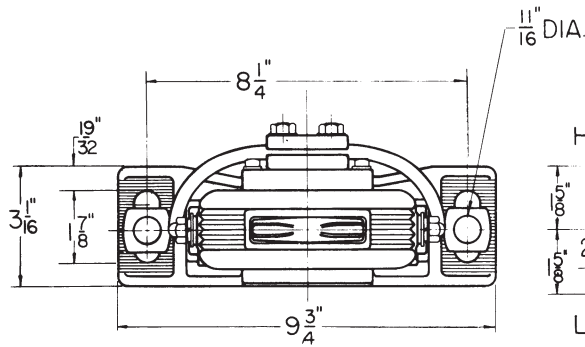
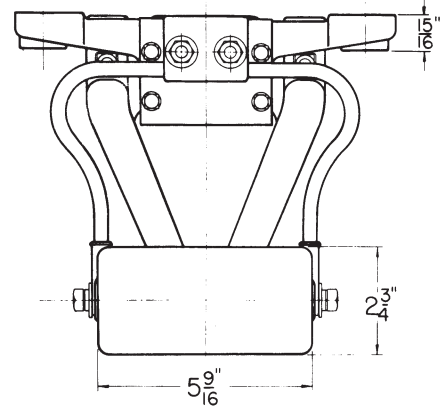

Catalog Information

Description	Extension B	Contact Member	*Range		Net Wt. Each — Lbs.	Catalog Number
			Up	Down		
LMI Collector — Overrunning	7 ³ / ₈ "	88810	1 ⁵ / ₈ "	1 ⁵ / ₈ "	16	95659
LMI Collector — Underrunning	7 ³ / ₈ "	88810	1 ⁵ / ₈ "	1 ⁵ / ₈ "	16	95660

* Range measurements apply to the vertical range with the collector in a horizontal position and measured from the point at the center of the member.

† When ordering, specify by catalog number.

**Collectors - Shoe Type
For Rigid Conductors
LM Pony Size**

Features

LM Pony and the LM Standard are similar in design, the LM Standard series being roughly twice the size of the LM Pony series and consequently has twice the current carrying capacity. Detailed characteristics of the two types are shown in this section. LM Standard series has a larger range of arm extension to suit numerous installation requirements.

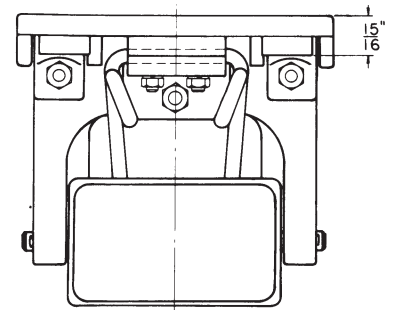

LM Pony Size (Underrunning)
98637
98634

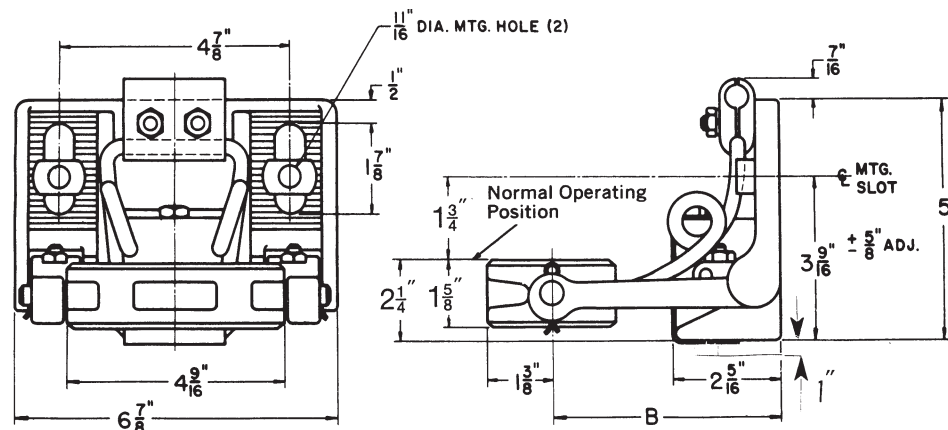
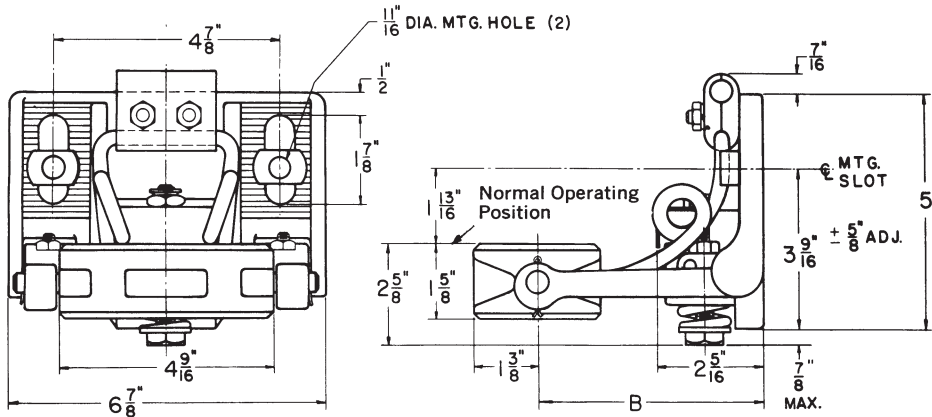

LM Pony Size (Overrunning)
76512
76514

Catalog Information

Description	Extension B	Contact Member	*Range		Net Wt. Each — Lbs.	Catalog Number
			Up	Down		
LM Pony — Underrunning	4 ¹⁵ / ₁₆ "	45650	5/8"	1"	12	98637
LM Pony — Overrunning	4 ¹⁵ / ₁₆ "	45650	1"	5/8"	12	76512
LM Pony — Underrunning	7 ³ / ₈ "	45650	1"	1 ⁵ / ₈ "	13	98634
LM Pony — Overrunning	7 ³ / ₈ "	45650	1 ⁵ / ₈ "	1"	13	76514

* Range measurements apply to the vertical range with the collector in a horizontal position and measured from the point at the center of the member.

Ordering Directions - Specify by Catalog Number.

**Collectors - Shoe Type
For Rigid Conductors
LM Standard Size**

Features

LM Pony and the LM Standard are similar in design, the LM Standard series being roughly twice the size of the LM Pony series and consequently has twice the current carrying capacity. Detailed characteristics of the two types are shown in this section. LM Standard series has a larger range of arm extension to suit numerous installation requirements.

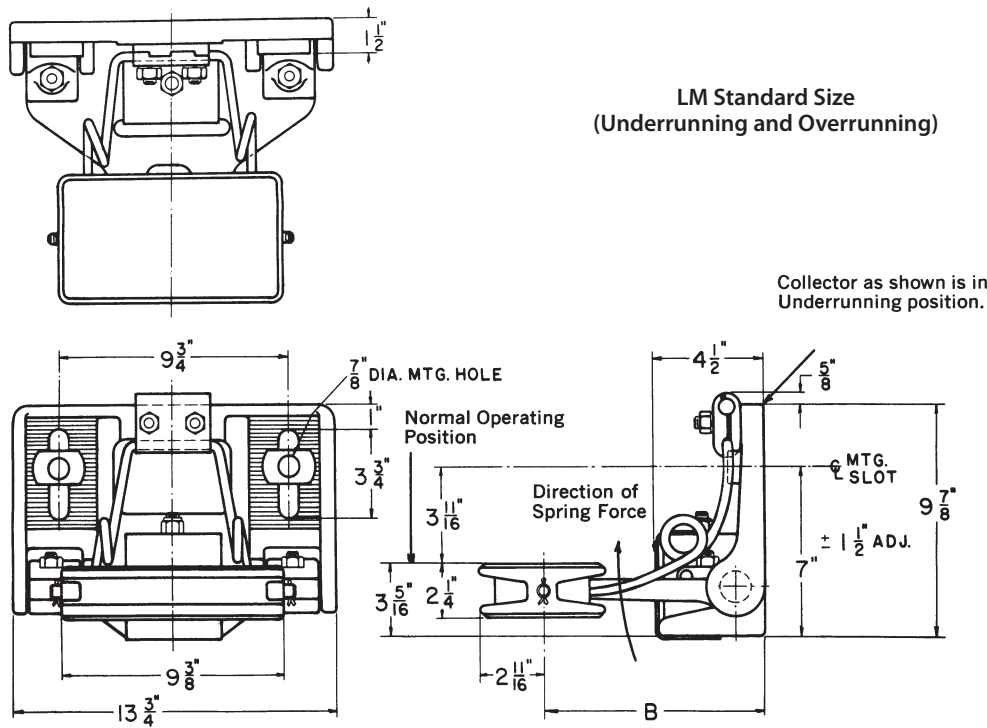

Catalog Information

Description	Extension B	Contact Member	*Range		Net Wt. Each — Lbs.	Catalog Number
			Up	Down		
LM Standard — Underrunning	9 ⁵ / ₁₆ "	45715	1"	1 ¹ / ₄ "	67	45712
LM Standard — Overrunning	9 ⁵ / ₁₆ "	45715	1 ¹ / ₄ "	1"	67	76507
LM Standard — Underrunning	10 ¹³ / ₁₆ "	45715	1 ¹ / ₄ "	1 ³ / ₈ "	69	45713
LM Standard — Overrunning	10 ¹³ / ₁₆ "	45715	1 ³ / ₈ "	1 ¹ / ₄ "	69	76508
LM Standard — Underrunning	12 ⁵ / ₁₆ "	45715	1 ¹ / ₂ "	1 ³ / ₄ "	71	45714
LM Standard — Overrunning	12 ⁵ / ₁₆ "	45715	1 ³ / ₄ "	1 ¹ / ₂ "	71	76509
LM Standard — Underrunning	15 ¹ / ₁₆ "	45715	1 ⁷ / ₈ "	2 ¹ / ₂ "	75	48474
LM Standard — Overrunning	15 ¹ / ₁₆ "	45715	2 ¹ / ₈ "	2 ¹ / ₈ "	75	76510

* Range measurements apply to the vertical range with the collector in a horizontal position and measured from the point at the center of the member.

Ordering Directions - Specify by Catalog Number.

**Collectors - Shoe Type
For Rigid Conductors
Type PS Collector**

Application

Type PS Collector with its exceedingly heavy construction is adaptable for severe service on pushing machines and quenching locomotives in coke oven operation.

Features

Collector consists primarily of rugged cast iron assembly, the extension arm is made from ductile iron designed to provide a pantograph action whereby the shoe contact member is always in line with the rail regardless of any normal amount of vertical or horizontal misalignment of either the contact or the running rails or both.

Heavy compression spring assures uniform pressure of the contact member on the conductor. A dust cover is provided to protect against contamination.

Main fulcrum points of the assembly are provided with bearings and the main shaft bearing is in addition provided with an oil cup.

Large replaceable shoe has a smooth contact surface of about 9" x 9". It is provided with two flexible braided copper shunts, each of which is provided with feeder terminals for 500 MCM cable.

Type PS collectors are supplied with four mounting holes. They can be mounted on four #89791 insulators .

Provision is made for vertical adjustment of the mounting height by means of a corrugated surface around an elongated mounting slot plus interlocking corrugated washers under the mounting bolts.

Replaceable contact members are available.

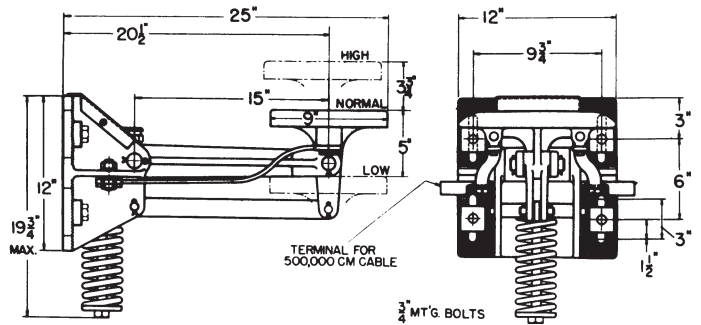
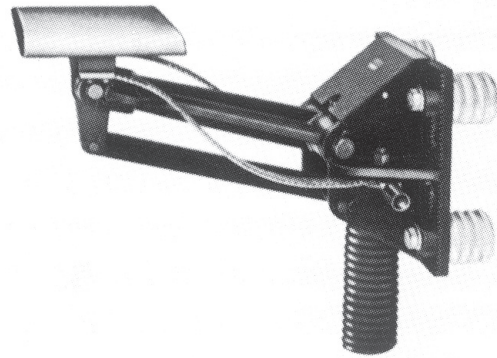

Catalog Information				
Description	Contact Member	*Approx. Current Rating Amperes	Net Wt. Each — Lbs.	Catalog Number
Type PS Underrunning Collector	77864	750 Constant 1500 Intermittent	185	75745
* Current carrying capacities are approximate as they depend upon conditions of installation such as speed, contact pressure, frequency of use, cleanliness of surfaces, etc.				

Ordering Directions - Specify by Catalog Number.

**Collectors - Shoe Type
For Rigid Conductors**

Comparison Chart				
	LMV Pony Series	LMI Pony Series	LM Pony Series	LM Standard Series
Approx. Current Capacity (Amperes) Average Conditions				
• Continuous Load	300	250	250	550
• Intermittent Load	600	500	500	1000
Contact Member	Two Contact Surfaces, each 1 1/2" x 9" including cleaning grooves. Cast Iron. Non-reversible.	Contact Surface 2 3/4" x 5 9/16" Cast Iron. Copper Coated. Reversible.	Contact Surface 2 1/2" x 4 1/2" Cast Iron. Reversible.	Contact Surface 5" x 9" Cast Iron Reversible.
Bronze Cable Terminals	Adjustable for wire diameters .414" to .528.	Adjustable for wire diameters .414" to .528.	Adjustable for wire diameters .414" to .528.	Adjustable for wire diameters .536" to .772.
Service	Underrunning	Under or Overrunning	Under or Overrunning	Under or Overrunning
Height of Mounting Back	5"	3 1/16"	5"	9 7/8"
Vertical Adjustment of Corrugated Mounting Washer	1 1/4"	1 1/4"	1 1/4"	3"
Mounting Bolt Diam. (Not Included with Collectors)	5/8"	5/8"	5/8"	3/4"
(Mounting Bolt Length depends on Mounting conditions.) Thickness of back and corrugated washer	15/16"	15/16"	15/16"	1 1/2"

Collectors - Contact Members For Rigid or Wire Conductors

Applications

The replaceable contacts for rigid or wire conductors in this section are those used with collectors previously listed.

Ratings are shown with the collectors. Bronze contacts in place of cast iron contacts are available in most sizes.

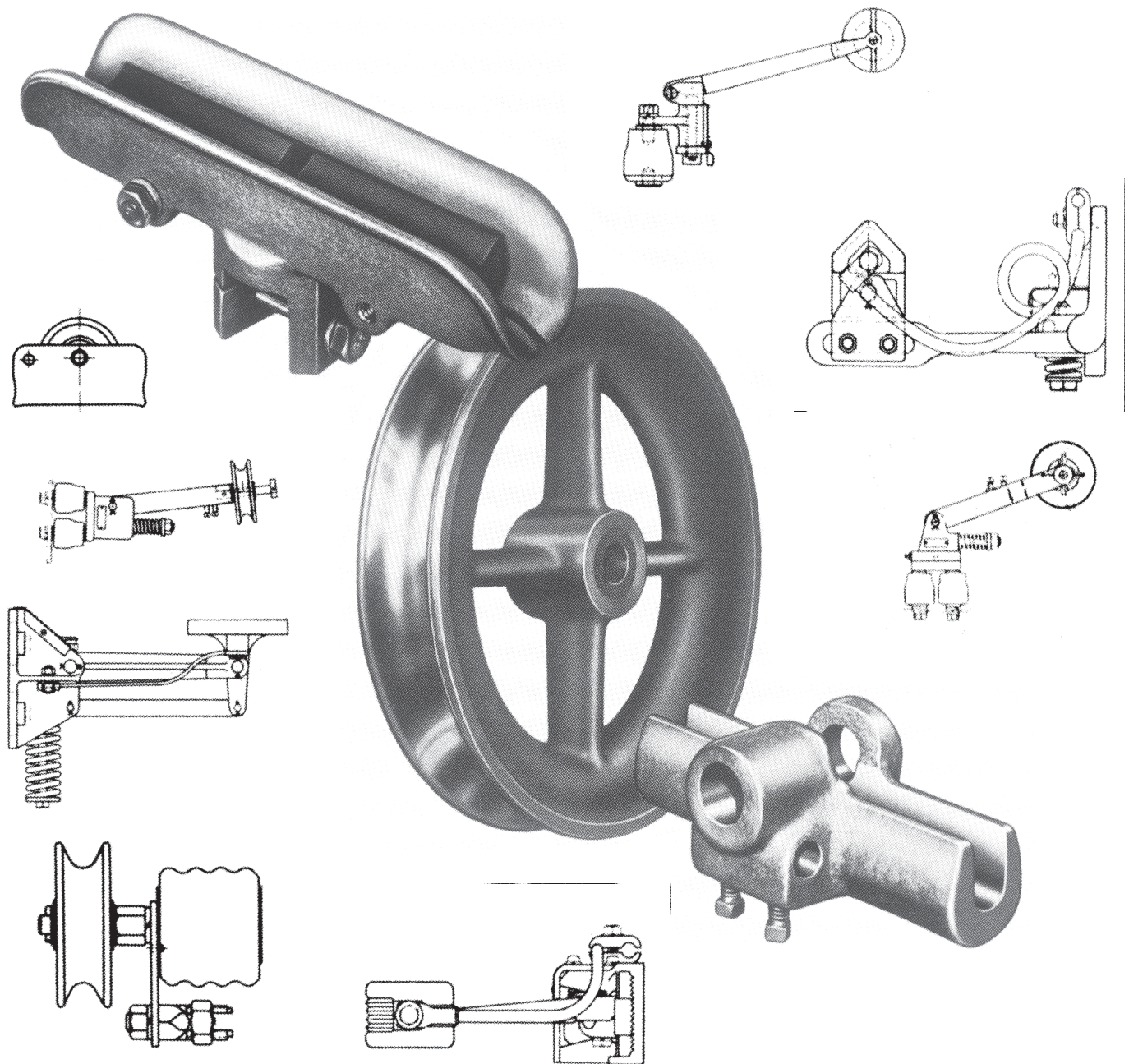

**Collectors - Contact Members
For Rigid Conductors**

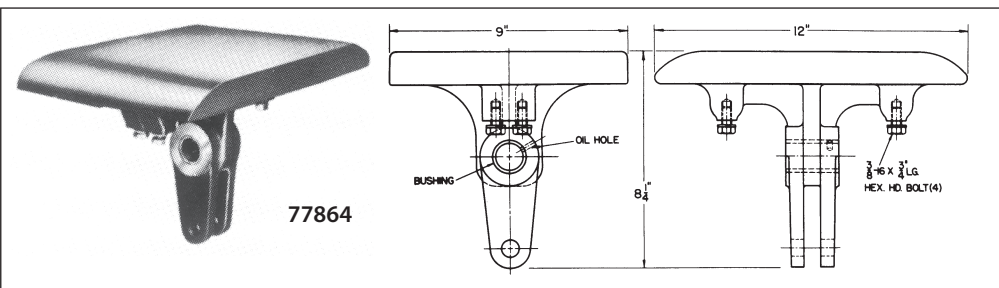
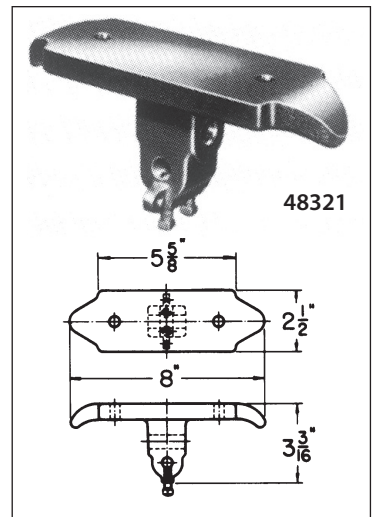
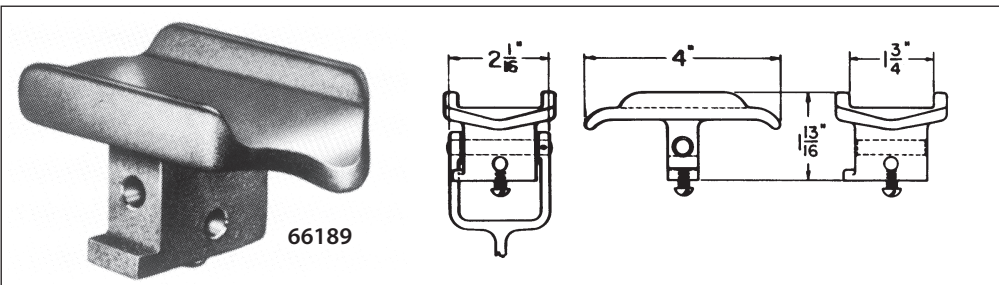
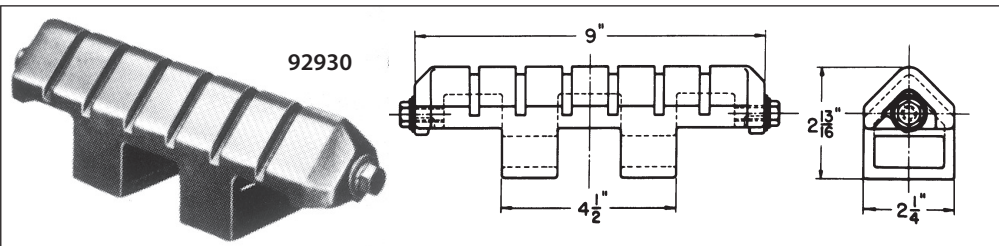
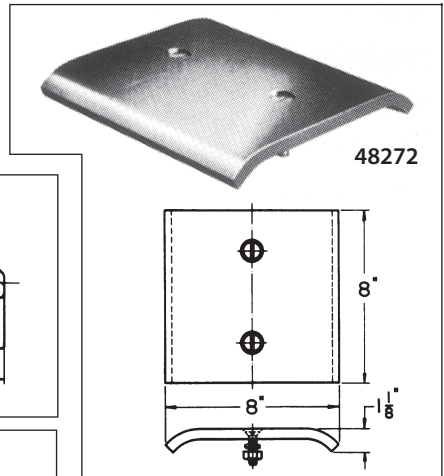
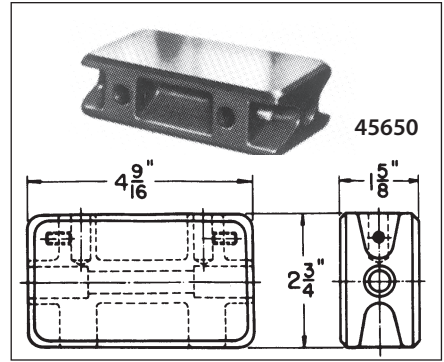
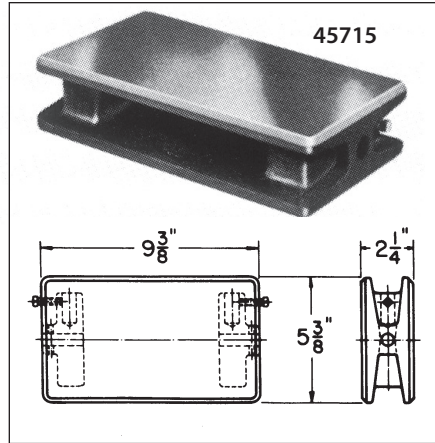
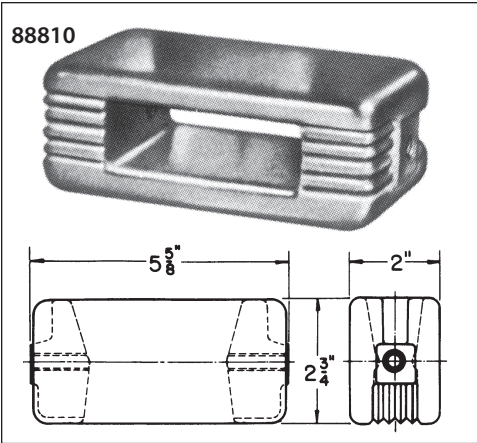

Catalog Information			
Description	Used on Collector	Net Wt. Each — Lbs.	Catalog Number
Cast Iron — Reversible Shoe	LMI — 95659, 95660	5.75	88810
Cast Iron — Reversible Shoe	LM Pony — 76512, 44276, 76514, 45674	3.125	45650
Cast Iron — Reversible Shoe	LM Standard—45712, 76507, 45713, 76508, 45714, 76509, 48474, 76510	18.75	45715
Cast Iron — Shoe	LMV — 67388, 78514, 98911, 986510	5.50	92930
Cast Iron — Shoe	PS — 72446, 75745	40.50	77864
Cast Iron — Support Only	Pantograph — 48480, 48271	13.00	48321
Steel plate contact for Cat. No. 48321	Pantograph — 48480, 48271	4.00	48272
Cast Bronze Shoe	Junior — 66188, 67263	1.25	66189

**Collectors - Contact Members
For Rigid Conductors**

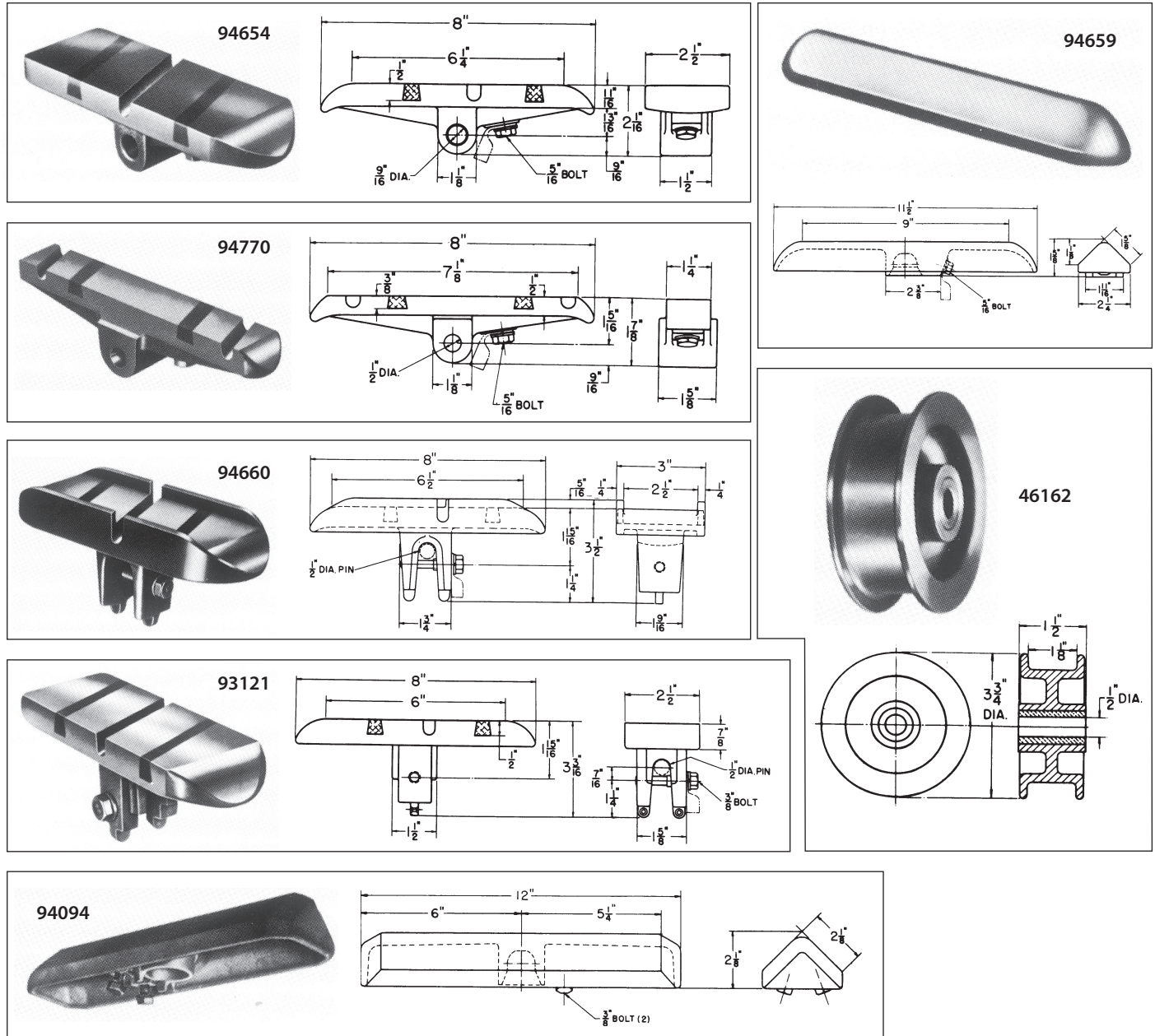

Catalog Information

Description	Used on Collector	Net Wt. Each — Lbs.	Catalog Number
Cast Iron Shoe with Carbon Inserts	Universal — 46192, Pantograph — 46628, 48287	4.00	93121
Bronze Wheel	Universal — 46227	2.25	46162
Cast Iron Shoe with Carbon Inserts	Universal — 94060, 94102	4.25	94654
Cast Iron Shoe with Carbon Inserts	Universal — 92868, 94103	2.00	94770
Cast Iron Shoe with Carbon Inserts	Universal — 94106	5.25	94660
Cast Iron Shoe	Universal — 94058	3.40	94659
Cast Iron Shoe	Universal — 94059	7.00	94094

Ordering Directions - Specify by Catalog Number.

**Collectors - Contact Members
For Wire Conductors**

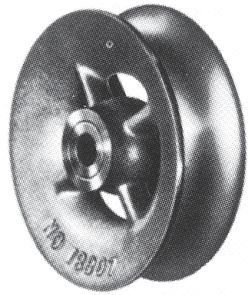

18897



46488

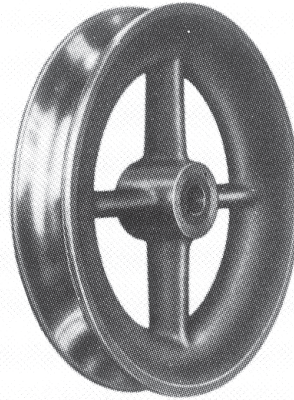

48384



60047

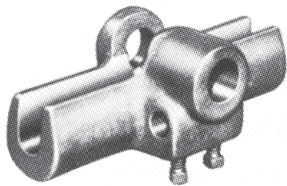

46615



62918

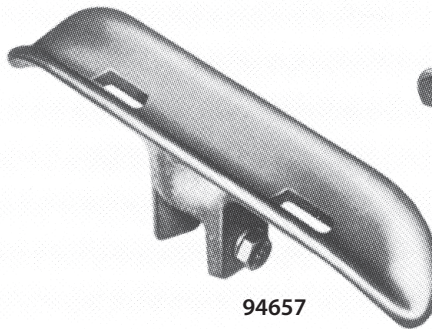

94657

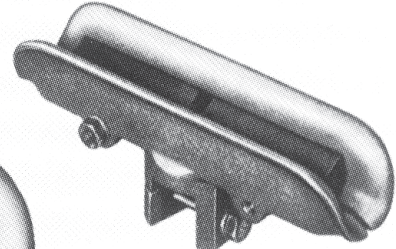

94658
94661

Catalog Information

Description	Used on Collector	Net Wt. Each — Lbs.	Catalog Number
Bronze Wheel — Spoked	46199, 46211 Universal 70545 Type PW, 46516 Pantograph	1.88	18897
Bronze Wheel — Solid	46492 Type BW	.69	46488
Bronze Wheel — Spoked	70086 Pantograph	7.13	48384
Bronze Wheel — Solid	60036, 60141 Junior	.88	60047
Bronze Shoe	46491 Type BV	1.81	46615
Bronze Shoe	62920, 60141 Junior	2.25	62918
Bronze Shoe	93148 Universal	2.38	94657
Bronze Shoe with Standard Inserts	92944 Universal	2.69	94658
Bronze Shoe with High Capacity Inserts	94136 Universal	3.63	94661
Standard renewable contact only	92944	.13	88321
High Capacity renewable contact only	94136	.44	88597

Ordering Directions - Specify by Catalog Number.

**Collectors - Contact Members
For Wire Conductors**

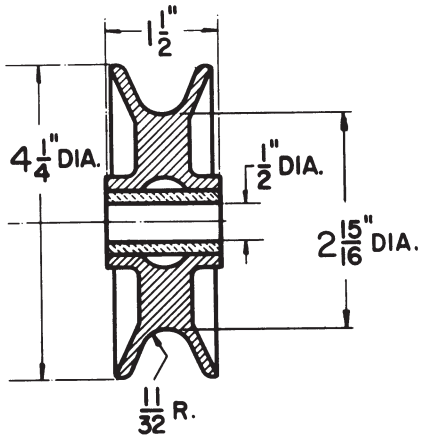

18897

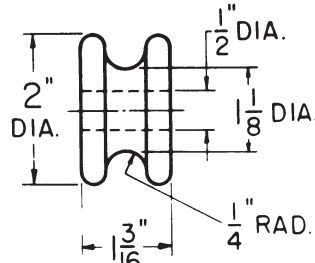

46488

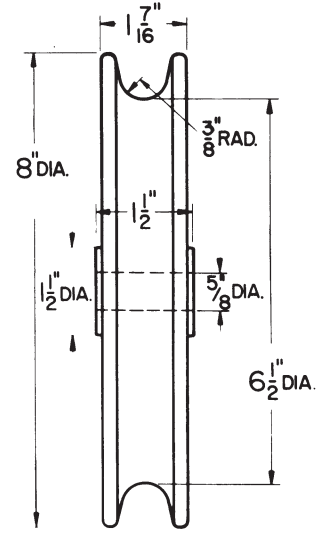

48384

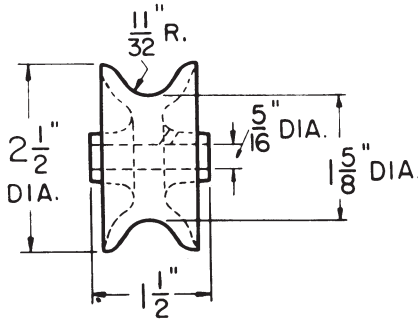

60047

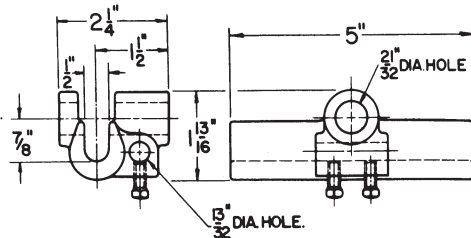

46615

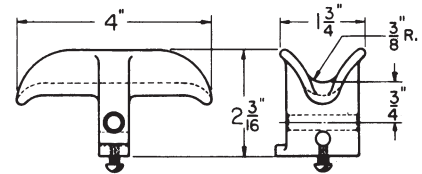

62918

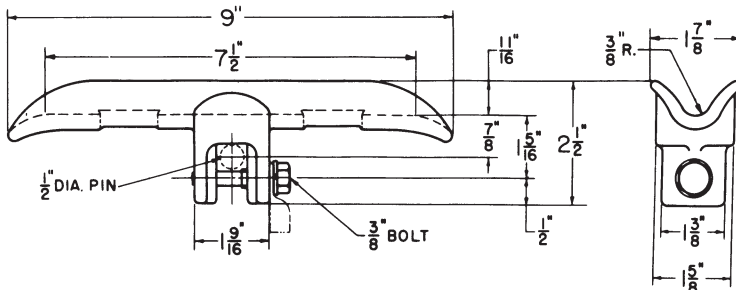

94657

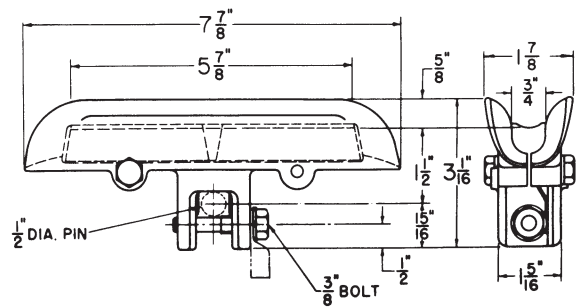

94658
94661



TranstTech
POWER TRANSFER SYSTEMS

The Leaders In Power Transfer Technology

TranstTech is a subsidiary of Fandstan Electric, a global group of companies focusing on energy transfer systems with installations in over 100 countries. Working synergistically with our European sister companies such as Brecknell-Willis, Stemmann and AKAPP, we are able to leverage a broad product portfolio and a wealth of technical expertise. Our goal is to better serve our power transfer markets by continuing to provide solutions that improve product life, performance, and reliability.

709 Augusta Arbor Way
Piedmont, SC 29673

800.245.4552 ph | 864.422.9027 fx
transtech.com

A Fandstan Electric Company